

## INSTRUCTION MANUAL

## DC-C30

### Mini Component System

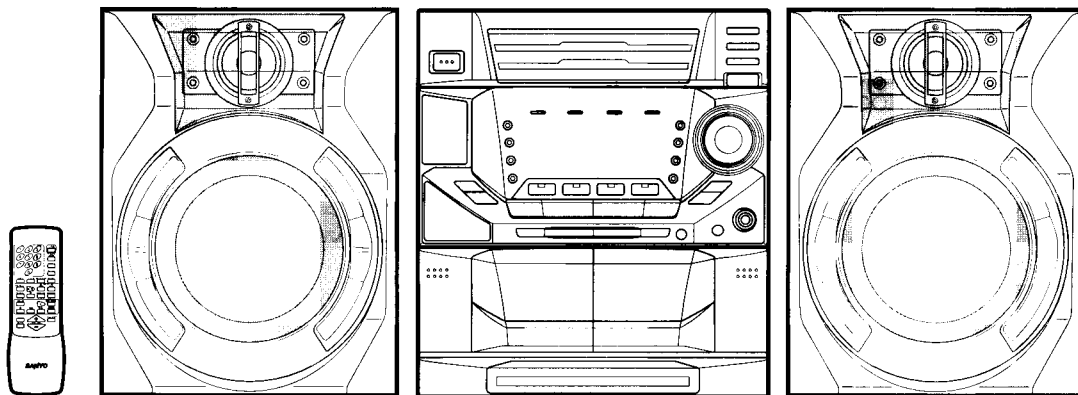

## SPECIFICATIONS

### Tuner

Reception frequency:  
FM: 87.5 - 108 MHz  
AM: 522 - 1710 kHz (9 kHz step)  
520 - 1710 kHz (10 kHz step)

### CD player

Type:  
Changer, 3-disc  
Channels:  
2-channel stereo  
Sampling frequency:  
44.1 kHz  
Pick-up:  
Optical 3-beam semiconductor laser  
Laser output:  
0.6 mW (Continuous wave max.)  
Wave length:  
790 nm  
Wow/flutter:  
Below measurable limits

### Cassette deck

Track system:  
4-track, 2-channel stereo  
Frequency response:  
120 Hz to 14 kHz  
Signal-to-noise ratio:  
48 dB  
Wow/flutter:  
0.12% (WRMS)  
Fast forward/rewind time:  
Approx. 110 sec. (C-60)

### General

Output power:  
20 W x 2 (at 6 ohms, 10% distortion)  
Input  
VIDEO/DVD IN: 550 mV/50k ohms  
Outputs  
SPEAKERS: 6 ohms  
PHONES: 8 - 32 ohms  
Power requirements:  
AC 230 - 240 V, 50 Hz  
Power consumption:  
65 W  
Dimensions:  
270(W) x 300(H) x 321(D) mm  
Weight:  
5.7 kg

### Speaker systems

Type:  
2 way bass reflex  
Unit used:  
Woofer: 12 cm cone type  
Tweeter: 5 cm cone type  
Maximum power-handling capacity:  
80 W (peak)  
Nominal impedance:  
6 ohms  
Dimensions:  
230(W) x 300(H) x 240(D) mm  
Weight:  
2.9 kg (per speaker)

Specifications subject to change without notice.

# PRECAUTIONS

CAUTION – INVISIBLE LASER RADIATION WHEN OPEN AND INTERLOCKS DEFEATED. AVOID EXPOSURE TO BEAM.

ADVARSEL – USYNLIG LASER STRÅLING VED ÅBNING, NÅR SIKKERHEDSAFBRYDERE ER UDE AF FUNKTION, UNDGÅ UDSÆTTELSE FOR STRÅLING.

VARNING – OSYNLIG LASER STRÅLNING NÅR DENNA DEL ÄR ÖPPNAD OCH SPÄRR ÄR URKOPPLAD. STRÅLEN ÄR FARLIG.

VORSICHT – UNSICHTBARE LASERSTRAHLUNG TRITT AUS, WENN DECKEL GEÖFFNET UND WENN SICHERHEITSVERRIEGELUNG ÜBERBRÜCKT IST. NICHT, DEM STRAHL AUSSETZEN.

VARO – AVATTAESSA JA SUOJALUKITUS OHITETTAESSA OLET ALTTIINA NÄKYMÄTTÖMÄLLE LASERSÄTEILYLLE. ÄLÄ KATSO SÄTEESEEN.



**CAUTION** – USE OF CONTROLS OR ADJUSTMENTS OR PERFORMANCE OF PROCEDURES OTHER THAN THOSE SPECIFIED IN THE OPERATING INSTRUCTIONS MAY RESULT IN HAZARDOUS RADIATION EXPOSURE. THE COMPACT DISC PLAYER SHOULD NOT BE ADJUSTED OR REPAIRED BY ANYONE EXCEPT PROPERLY QUALIFIED PERSONNEL.

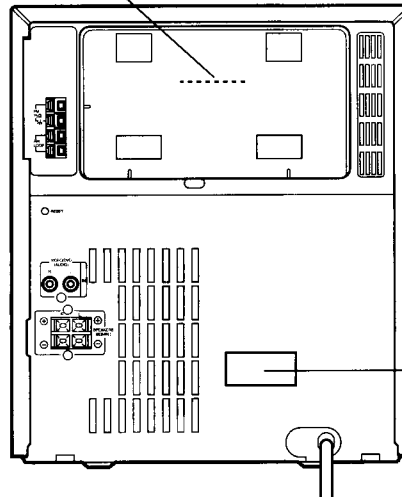

CLASS 1 LASER PRODUCT  
LUOKAN 1 LASERLAITE  
KLASS 1 LASERAPPARAT

- The apparatus shall not be exposed to dripping or splashing.
- Do not use where there are extremes of temperature (below 5°C or exceeding 35°C) or where direct sunlight may strike it.
- Because of the CD player's extremely low noise and wide dynamic range, there might be a tendency to set the volume on the amplifier unnecessarily high. Doing so may produce an excessively large output from the amplifier which could damage your speakers.
- Sudden changes in the ambient temperature may cause condensation to form on the optical lens inside the unit. If this happens, take out the disc, leave the unit for about 1 hour, and then proceed to operate.
- **When carrying the unit, be sure to remove any discs which may be inside and turn the power off. Wait at least 10 seconds, then unplug the mains lead from the AC outlet. Carrying the unit with any discs inside may damage the discs and/or the unit.**

- The system's speakers use powerful magnets. Do not place timepieces, credit cards, cassette tapes or video tapes, etc. near the speakers.
- Do not install this equipment in a confined space, such as a book case or built in cabinet.

Recording copyright material without permission of the copyright owners is usually an infringement. If you wish to re-record copyright material, permission from the copyright owner is necessary. SANYO does not approve of, and cannot be held responsible for, any unlawful use of this machine.

# CONNECTIONS

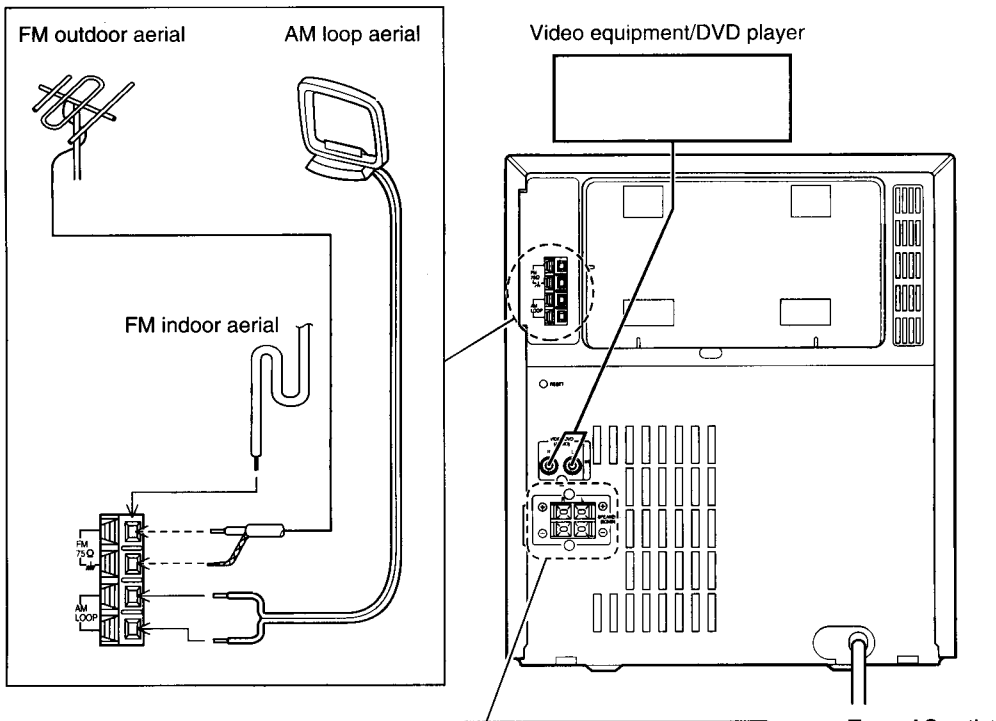

To an AC outlet

## Note:

- Do not connect the mains lead to an AC outlet until all connections have been made.
- The system is not completely disconnected from the mains when the /ON button is set to the position.

When the unit is first connected, the display switches automatically to the demonstration mode. To cancel this mode, turn the power on or press the DISPLAY button.

## Speakers

When connecting the speakers, make sure that (+) and (-) polarities are matched properly. Otherwise, the sound may appear to be lacking in the bass range and in stability. Connect the speaker wire with the stripe to the red terminal (+) and the other wire to the black terminal (-).

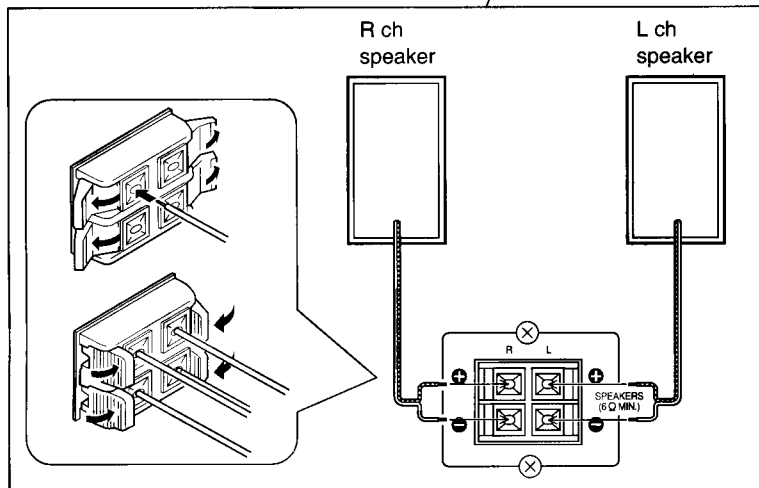

## FM aerial

The FM indoor aerial is sufficient to receive most local FM broadcasts and should be connected to the FM 75 Ω terminal. Extend the aerial wire as straight as possible and, while listening to the sound from the system, secure it in a position which yields minimal distortion and noise. In fringe areas or where reception is distorted or noisy, an FM outdoor aerial (not supplied) should be connected instead of the indoor aerial. The terminals will accept 75-ohm coaxial cable. Consult your dealer.

## AM loop aerial

Assemble the loop aerial as shown in figure. Unwind the aerial wires, then connect them to the AM LOOP terminals. Place the loop aerial in a position which yields the best AM reception, or attach it to a wall or other surface as shown in figure.

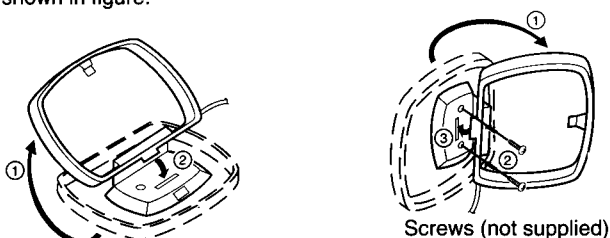

## Note:

To minimize noise, the speaker, mains and any other leads should not come close to the FM indoor or outdoor aerial lead and AM loop aerial. Do not place the aerial leads close to the system.

## Video equipment/DVD player

Connect audio leads (not supplied) from the audio output sockets of a video equipment/DVD player to the VIDEO/DVD IN sockets.

## Headphones

Connect stereo headphones (not supplied) to the PHONES socket for monitoring or for private listening. The speakers are automatically disconnected when headphones are connected.

# CONTROLS

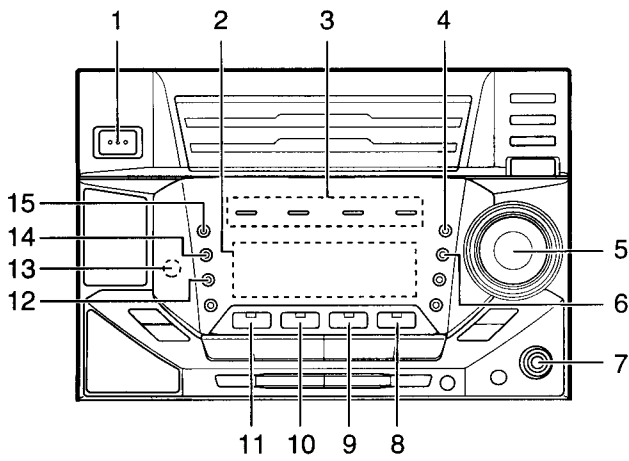

## General

1. Power button (⏻/ON)
2. Display
3. Sound preset indicators (POP/ROCK/CLASSIC/JAZZ)
4. Sound preset button (SOUND PRESET)
5. Volume control (VOLUME)
6. Bass expander button (BASSXPANDER)
7. Headphones socket (PHONES)
8. Video/DVD function button (VIDEO/DVD)
9. Tuner function/Band select button (TUN/BAND)
10. Tape function/Deck select button (TAPE A/B)
11. CD function button (CD)
12. Timer button (TIMER)
13. Remote sensor
14. Clock button (CLOCK)
15. Display button (DISPLAY)

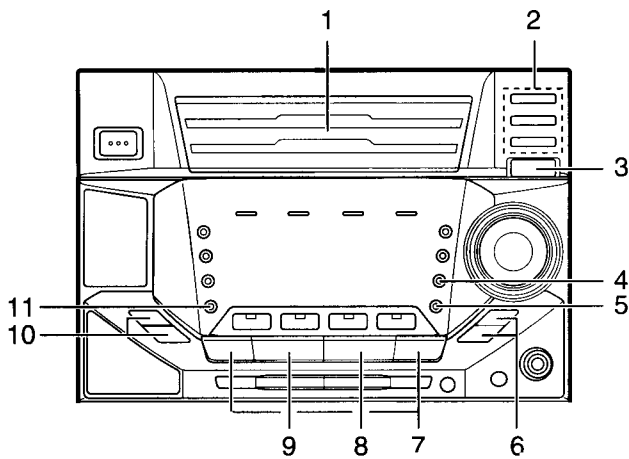

## CD player/Tuner

1. Disc trays
2. Disc select buttons (DISC 1, DISC 2, DISC 3, DISC SELECT)
3. Disc tray open/close button (OPEN/CLOSE)
4. Memory button (MEMORY)
5. Edit button (EDIT)
6. Tuning buttons (TUNING)
7. Skip/Search buttons (⏮/⏪, ⏩/⏭)
8. Play/Pause button (▶/⏸)
9. Stop button (■)
10. Preset tuning buttons (PRESET)
11. FM mode select button (FM MODE)

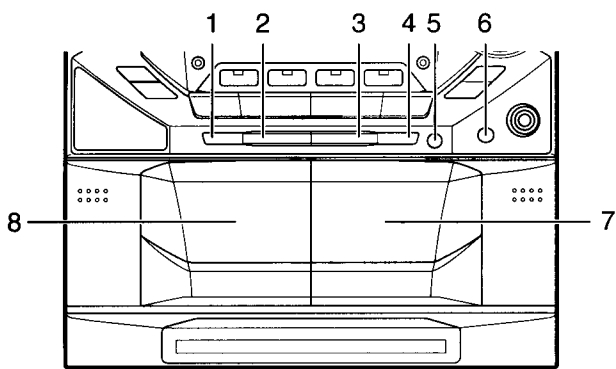

## Cassette deck

1. Rewind button (⏮)
2. Stop button (■)
3. Play button (▶)
4. Fast forward button (⏭)
5. Record/Record pause button (REC PAUSE)
6. Computer recording button (COMP. REC)
7. Deck B cassette holder
8. Deck A cassette holder

# REMOTE CONTROL

## Controls

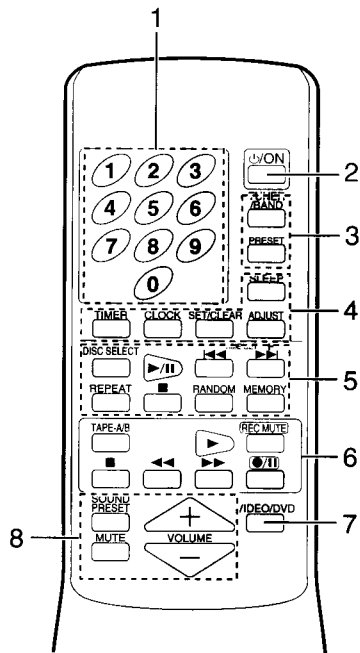

### Number buttons (1 - 9, 0)

These buttons are used to select the track numbers on a disc or preset radio stations.

If the function is "CD", the buttons select the track numbers on a disc. If the function is "TUNER", the buttons select preset radio stations.

With any other function, the buttons will not function.

- Two buttons must always be pressed.

Example:

To select No. 3, press 0, then 3.

To select No. 10, press 1, then 0.

To select No. 25, press 2, then 5.

### Inserting batteries

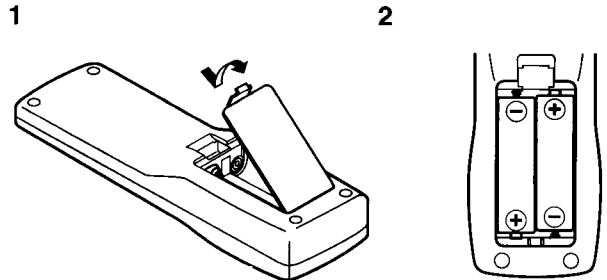

Two R6/AA batteries (not supplied)

1. Number buttons (1 - 9, 0)
2. Power button (ON)
3. Tuner controls  
TUNER/BAND: Tuner function/Band select button  
PRESET: Preset tuning button
4. Clock/Timer controls  
SLEEP: Sleep timer button  
TIMER: Timer button  
CLOCK: Clock button  
SET/CLEAR: Set/Clear button  
ADJUST: Adjust button
5. CD player controls  
DISC SELECT: Disc select button  
▶/||: Play/Pause button  
TIME SET/◀◀, ▶▶: Time set/Skip/Search buttons  
REPEAT: Repeat button  
■: Stop button  
RANDOM: Random play button  
MEMORY: Memory button  
(This button can also be used as a tuner memory button.)
6. Deck controls  
TAPE-A/B: Tape function/Deck select button  
▶: Play button  
REC MUTE: Record muting button  
■: Stop button  
◀◀: Rewind button  
▶▶: Fast forward button  
●/||: Record/Record pause button
7. Video/DVD function button (VIDEO/DVD)
8. General controls  
SOUND PRESET: Sound preset button  
MUTE: Audio muting button  
VOLUME: Volume buttons

Note:

Always remove batteries if the remote control is not to be used for a month or more. Batteries left in the unit may leak and cause damage.

### Remote control range

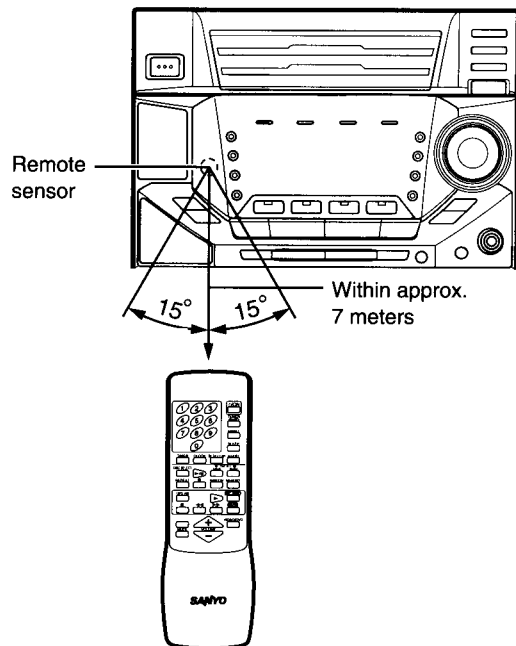

The buttons on the remote control perform similar functions to similarly marked buttons on the front panel.

# ADJUSTING THE CLOCK

Example: To set "PM 6:30",

1. Press the  $\odot$ /ON button to turn the power on.
2. Press the CLOCK button. The clock display appears.
3. Press the MEMORY (or ADJUST) button within 10 seconds.

When using the main unit, use the MEMORY,  $\blacktriangleright\blacktriangleright\blacktriangleright$  and  $\blacktriangleleft\blacktriangleleft\blacktriangleleft$  buttons.  
When using the remote control, use the ADJUST, + and - TIME SET buttons.

AM 12:00

The hours display blinks.

4. Press the  $\blacktriangleright\blacktriangleright\blacktriangleright$  or  $\blacktriangleleft\blacktriangleleft\blacktriangleleft$  (or + or - TIME SET) button to set the "hours."

PM 6:00

5. Press the MEMORY (or ADJUST) button.

PM 6:00

The minutes display blinks.

6. Press the  $\blacktriangleright\blacktriangleright\blacktriangleright$  or  $\blacktriangleleft\blacktriangleleft\blacktriangleleft$  (or + or - TIME SET) button to set the "minutes."

PM 6:30

7. Press the MEMORY (or ADJUST) button. The clock starts.

PM 6:30

- The time can be set accurately by pressing the MEMORY (or ADJUST) button when a time signal is heard.
- To display the clock during operation, press the CLOCK button. Press it again to return to the original display.
- When the display blinks because of a power failure, reset the time.

## BEFORE OPERATION

### Turning the power on and off

Press the  $\odot$ /ON button. The displays light. (After connecting the mains lead, when you press the  $\odot$ /ON button for the first time, the volume reset feature automatically sets the initial volume level.)

To turn the power off, press the  $\odot$ /ON button again. The clock display remains lit. (If the clock has not been set, the display enters the demonstration mode.)

- When the mains lead is connected to the AC outlet, the unit will respond to commands from the remote control.

### Smart start function

If the following buttons are pressed when the unit is in standby, the unit turns on automatically and the selected function is set.

CD section	CD, $\blacktriangleright\blacktriangleright\blacktriangleright$ , DISC 1, DISC 2, DISC 3, OPEN/CLOSE
Tuner section	TUN/BAND
Cassette section	TAPE A/B, $\blacktriangleright$
Video/DVD section	VIDEO/DVD
Remote control	$\blacktriangleright\blacktriangleright\blacktriangleright$ , TUNER/BAND, TAPE-A/B, $\blacktriangleright$ , VIDEO/DVD

### Selecting the function

Press the desired function button (CD, TAPE A/B, TUN/BAND or VIDEO/DVD).

The function is automatically selected when CD play or tape playback is started, or when the TUN/BAND button has been pressed (except during recording or tape dubbing).

- When the function selection is changed, CD play or tape playback is automatically stopped.

### Adjusting the volume

Turn the VOLUME control, (or press the + or - VOLUME button on the remote control). The volume level appears by numbers (VOL 0 ~ VOL MAX) and bar-graph on the display.

### To reduce the volume temporarily (muting)

Press the MUTE button on the remote control. "MUTE" blinks on the display. To restore the previous volume setting, press the MUTE button again. "MUTE" disappears.

### Bass expander system

Press the BASSXPANDER button to enhance the bass sound. "BASS" appears on the display.

- The initial setting of this function is ON.

### Selecting the sound mode

Press the SOUND PRESET button to select the sound mode matching the music to be listened to.

- POP: Pops, etc.
- ROCK: Rock music, etc.
- CLASSIC: Classical music, etc.
- JAZZ: Jazz, etc.

### Demonstration mode

If the DISPLAY button is pressed, the display enters the demonstration mode. To cancel this mode, press the DISPLAY button again.

### WHAT TO DO IF ...

If the operation of the unit or display is not normal,

1. Disconnect the mains lead.
2. Press the RESET button (rear of the unit) for at least 30 seconds.
3. Connect the mains lead.
4. Resume the operation.

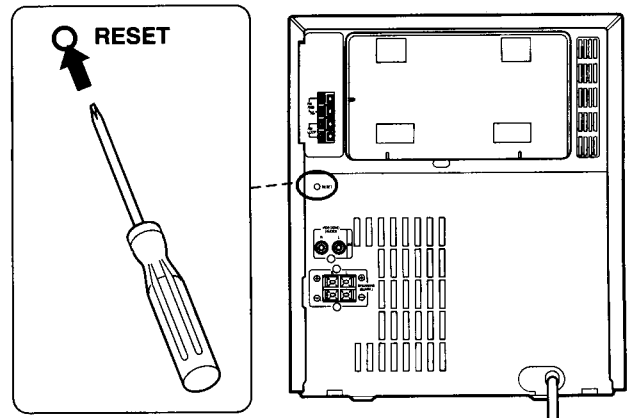

# CD PLAY

Use compact discs bearing the symbol shown below. In addition to conventional 12 cm CDs, this system can be used to play 8 cm CDs without an adapter.



#### Note:

- Do not touch the disc tray while it is moving.
- Never place anything except a compact disc on the disc tray. Foreign objects can damage the unit.
- Do not apply excessive force to the disc tray.
- Discs must be placed on the disc tray one at a time.

If discs are loaded, you can turn the unit on and begin play immediately by pressing the ►/||, DISC 1, DISC 2 or DISC 3 button.

1. Press the CD button to select "CD" function. "CD" appears on the display, then "CD" is replaced by "DISC". "1" disc number blinks.
2. Press one of the DISC SELECT buttons (DISC 1, DISC 2 or DISC 3), then press the OPEN/CLOSE button.
  - If the changer mechanism has detected "NO DISC" for the DISC SELECT button pressed, the tray slides out automatically. The selected disc tray slides out. "OPEN" appears and the selected disc number blinks on the display.
3. Place the disc with the label facing up on the disc tray.

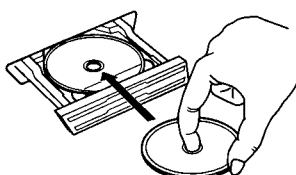

For 12 cm CD

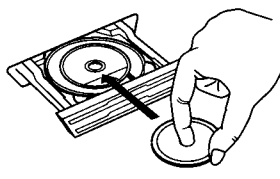

For 8 cm CD

4. Press the OPEN/CLOSE button again to close the disc tray.  
**Note:**  
To open or close the disc tray, be sure to use the OPEN/CLOSE button. Do not touch the disc tray by hand.
5. Repeat steps 2 - 4 to load another disc.
6. Press one of the DISC SELECT buttons (DISC 1, DISC 2 or DISC 3).



"▷" appears, and play starts from the first track of the selected disc. The track number and elapsed playing time for the current track are displayed.

- If the desired disc number has been selected, the ►/|| button can also be used to start play.

#### Note:

If the disc is loaded with the label facing downward, or if a badly scratched disc is loaded, "NO DISC" appears on the display. If this occurs, load the disc correctly or replace the damaged disc.

7. Press the ■ button (CD section) to end disc play.  
When the last track of the last disc has been played, the player stops automatically.
  - When the OPEN/CLOSE button is pressed during play, play will stop and the disc tray will slide out.

## Ejecting or replacing discs

1. While in the CD play or stop mode, press one of the DISC SELECT buttons to be ejected, then press the OPEN/CLOSE button.
  - While the player is playing one disc, you can eject or replace another disc without stopping play.
2. Remove or replace the disc.
3. Press the OPEN/CLOSE button.

## Notes on handling compact discs

- Do not expose the disc to direct sunlight, high humidity or high temperatures for extended periods of time.
- Discs should be returned to their cases after use.
- Do not apply paper or write anything on the disc surface.
- Handle the disc by its edge. Do not touch the playing surface (glossy side).
- Fingerprints and dust should be carefully wiped off the playing surface of the disc with a soft cloth.  
Wipe in a straight motion from the centre to the outside of the disc.
- Never use chemicals such as record cleaning sprays, antistatic sprays or fluids, benzene or thinner to clean compact discs.

## To start play from the desired track

1. Press the desired DISC SELECT button, then press the ■ button.
2. Select the desired track by using the ►►/►► or ◀◀/◀◀ button, then press the ►/|| button.

## Using the remote control

1. Select the desired disc by pressing the DISC SELECT button, then press the ■ button (CD section).
2. Press two number buttons to select the desired track.

## Temporarily stopping play

Press the ►/|| button. "▷" blinks on the display. To resume play, press the button again.

## Skip play

To skip to track 6 while track 3 is playing, press the ►►/►► button repeatedly until "6" appears in TR on the display. To skip back to track 3 while track 6 is playing, press the ◀◀/◀◀ button repeatedly until "3" appears.

- The number buttons on the remote control can also be used for skip play. To skip to track 6 while one track is playing, press 0, then 6.

## Search (forward/reverse)

If the ►►/►► or ◀◀/◀◀ button is pressed during play, the player will search at high speed in the forward or reverse direction while the button is being pressed. When the button is released, normal play will continue.

## Random play

Press the RANDOM button on the remote control to begin random play. The player will automatically select and play discs and tracks at random. "RANDOM" appears on the display.

- Random play will not function during programmed play.

## Repeat play

Press the REPEAT button on the remote control repeatedly to select the desired repeat mode in the following sequence. The selected repeat mode is shown on the display.

- REPEAT ONE: Repeat one track.
- REPEAT ALL: Repeat all tracks on the selected disc.
- REPEAT CONT: Repeat all tracks on all discs.
- Released: Normal play mode

#### Note:

During programmed play, "REPEAT CONT" can not be selected.

## Changing discs during play

While the player is playing one disc, press one of the DISC SELECT buttons to skip to another disc. "CH DISC" blinks for a few seconds, then the selected disc moves into playing position. Play starts automatically from the first track on the disc.

## PROGRAMMED PLAY

Up to 32 tracks, from up to 3 discs, can be programmed for play in any order.

- To begin the programming procedure, select "CD" function first.
- The discs or tracks must be programmed in the stop mode.
- The same disc or track can be programmed more than once.

Follow the example below to programme tracks 6 and 2 on DISC 1 and all tracks on DISC 3. In this example, each disc has 9 tracks and DISC 3 is in playing position.

1. Press the MEMORY button.

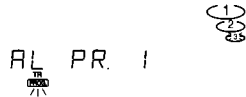

2. Select disc 1 by pressing the DISC 1 button.

- The DISC SELECT button on the remote control can also be used.

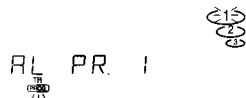

3. Select track 6 by pressing the ►►/►► button.

- The number buttons on the remote control can also be used.

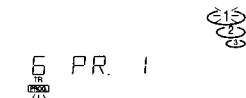

4. Press the MEMORY button. "PROG." remains lit.

5. Select track 2 by pressing the ◀◀/◀◀ button.

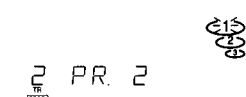

6. Press the MEMORY button. "PROG." remains lit.

7. Select disc 3 by pressing the DISC 3 button

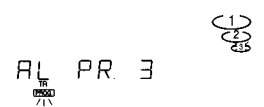

8. Press the MEMORY button. "PROG." remains lit.

9. Press the ►/|| button to start play.

When all programmed tracks have been played, the player stops automatically. "0 0.00" appears on the display.

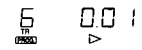

- The programme contents are retained in memory.

- Any attempt to programme more than 32 tracks will result in "FULL" being displayed and discontinuation of the programming.
- If a non-existent disc or track number is programmed, that disc or track will be skipped during play.
- The programme is cleared when the ■ button is pressed in the stop mode.

### Checking the programme

Each time the MEMORY button is pressed in the stop mode, the programmed details sequentially appear on the display.

### Changing a programme

#### To add a new track to a programme:

1. In the stop mode, press the MEMORY button repeatedly until "- - -" is displayed.
2. Select a disc and track as explained above.
3. Press the MEMORY button.

#### To change a track:

1. In the stop mode, press the MEMORY button repeatedly until the track number to be replaced is displayed.
2. Select a disc and track as explained above.
3. Press the MEMORY button.

Note:

Programmed details cannot be partially deleted or inserted.

## LISTENING TO TAPES

Deck A is for playback only; deck B is for both playback and recording.

If a cassette is loaded, you can turn the unit on and begin play immediately by pressing the ► button.

1. Press the TAPE A/B button to select "TAPE". "TAPE" appears on the display.
2. Press the cassette holder (EJECT portion) to open it.
3. Load the cassette(s).

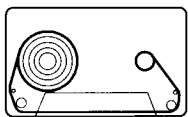

DECK A

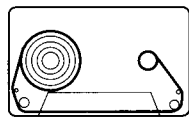

DECK B

After loading the cassette(s), push the cassette holder (EJECT portion) back into position. "A" or "B" appears on the display.

4. Select deck A or deck B by pressing the TAPE A/B button if required. (If only one cassette is loaded, deck A or deck B will be selected automatically.)
5. Press the ► button to begin playback.



6. Press the ■ button (Deck section) to stop playback at any time. When the end of the tape has been reached, automatic stop will be activated.

Note:

- Use the normal tape (TYPE 1).
- Endless tapes cannot be used.
- Do not use C-100 (or longer) tapes. They may jam in the mechanism.

### Fast forward and rewind

Press the ►► or ◀◀ button. "▶" or "◀" blinks. When the desired location has been reached, press the ■ button.

### Tape counter

Each deck has a counter. The counter of the selected deck appears on the display and helps you to quickly locate the recorded selection for playback.



Both sides of the counter indicate tape movement with rotating graphic displays.

#### To reset the tape counter to "000"

In the stop mode, press the TAPE A/B button to select the counter to be reset, then press the ■ button.

- When the tape is automatically rewound during CD computer recording or tape computer dubbing, the counter automatically resets to "000".

### Relay playback

1. Load the cassettes into both decks.
2. Select deck A or deck B by pressing the TAPE A/B button if required.
3. Press the ► button.

DECK A → DECK B.  
DECK B → DECK A.



# LISTENING TO THE RADIO

## Before use

When the unit is shipped from the factory, its AM frequency band is set as "522 - 1710 kHz (in 9 kHz steps)".

If your local AM broadcast system is organized in 10 kHz steps, change the frequency band to "520 - 1710 kHz (in 10 kHz steps)" as follows.

1. Press the TUN/BAND button to select "AM".
2. While pressing the MEMORY button on the front panel, press the ■ button (CD section) on the front panel.

To return the original setting, repeat steps above.

To turn the unit on and listen to the last received station, press the TUN/BAND button.

## Automatic/Manual tuning

1. Press the TUN/BAND button to select FM or AM.
  - "TUNER" appears on the display, then "TUNER" is replaced by the tuner mode display.

### Automatic tuning

Press the ▽ or △ TUNING button for at least 0.7 seconds to tune in a station. The unit will scan up or down the band and receive the next receivable station. Press the button again to continue.

### Manual tuning

Press the ▽ or △ TUNING button briefly until the desired frequency is displayed.

FM 103.25 MHz

## To preset stations

Up to 24 stations for FM band, and up to 12 stations for AM band can be preset.

### Automatic presetting (APT)

1. Press the TUN/BAND button to select FM or AM.
2. Press and hold down the MEMORY button for at least 3 seconds. "PRESET" blinks.

The automatic tuning mode is set and automatic presetting begins from the low end of the band.

When 24 stations for FM or 12 stations for AM have been preset or the high end of the band is reached, automatic presetting stops. "PRESET" disappears and the station memorized on channel 1 will be heard.

3. To preset stations on the other band, follow steps above.

### Note:

If APT is activated, all previously programmed stations of the band will be cleared and new stations will be programmed.

### Manual presetting

1. Tune in the station to be preset as described in "Automatic/Manual tuning".
2. Press the MEMORY button.

-- 103.25 MHz  
PRESET  
/ \

3. Press the ▽ or △ PRESET button to select the channel to be preset.

9 103.25 MHz  
PRESET  
/ \

4. Press the MEMORY button.
  - In this example, "103.25 MHz" FM station is preset on FM channel 9.
  - The number buttons on the remote control can be used to select the preset station. In this example, press 0, then 9 after the step 2 above.

FM 103.25 MHz

### Note:

If the next step is not taken within 10 seconds while performing steps 2 - 4, "PRESET" disappears and the preset operation is cancelled. Press the MEMORY button to continue.

5. Repeat steps above to add more preset stations.

- When presetting a new station, the previous preset station is cleared.

## Listening to preset stations

1. Press the TUN/BAND button to select FM or AM.
2. Press the ▽ or △ PRESET button briefly to select the desired channel.
  - The number buttons on the remote control can also be used. Press two number buttons within 4 seconds.

### Preset scan tuning

1. Press the TUN/BAND button to select FM or AM.
2. Press the ▽ or △ PRESET button for at least 0.7 seconds. The channel number blinks on the display. Each of the preset stations is tuned in for 5 seconds.
3. When the desired station has been tuned in, press the ▽ or △ PRESET button again to keep the reception locked at that station.

## To receive FM stereo broadcasts

Make sure that "MONO" is not displayed. If "MONO" appears, press the FM MODE button to turn the "MONO" indication off.

"ST" appears when an FM stereo broadcast is received.

- If the signal from an FM stereo station is weak and reception is poor, press the FM MODE button to change to monaural reception. The reception may be improved, but the sound will be monaural.

### When beat interference is heard

A high-pitched noise called "beat" is sometimes heard during reception of radio broadcasts. If this occurs,

1. Press the MEMORY button.
2. While "PRESET" is blinking, press the ◀◀/▶▶ button to select "bc-A" or "bc-B". Select the setting that gives the best results.

# LISTENING TO VIDEO SOURCES/DVD

1. Press the VIDEO/DVD button. "VIDEO: DVD" appears on the display.
2. Follow the instructions supplied with the video equipment/DVD player.

# BEFORE RECORDING AND DUBBING

Use deck B for recording.

## Automatic record muting

Undesirable parts of a programme can be omitted while recording. Press the REC MUTE button on the remote control once while recording. "REC" blinks on the display and a 5-second unrecorded blank space is created, then the cassette deck enters the record pause mode. "REC" remains lit and "▶" blinks on the display.

- To add another 5-second blank space, press the REC MUTE button again.
- To resume recording, press the ▶ button.

Note:

The record muting function does not operate during CD computer recording or tape computer dubbing.

## Safeguards against accidental erasure

Accidental erasure can be prevented by breaking out the tabs on the end of the cassette tape (where the tape is not exposed) using a screwdriver or similar implement.

If a tab is broken out in error and you wish to re-record the tape, simply block the tab hole using adhesive tape and the tape can be used for recording again.

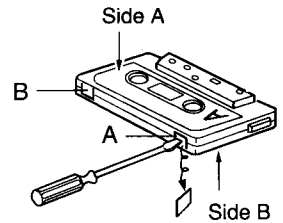

Break out tab A for side A.  
Break out tab B for side B.

# RECORDING

## RECORDING COMPACT DISCS

### Computer recording

With computer recording, you can record a CD onto a cassette by pressing just one button.

1. Load the disc(s) to be recorded.
2. Load a blank cassette into deck B.
3. Select "CD" function.
  - For programmed recording from up to 3 discs, programme the material in advance (as described under "PROGRAMMED PLAY").
4. Press the DISC SELECT button (DISC 1, DISC 2 or DISC 3) to select the disc to be recorded first, then press the ■ button (CD section).
  - For programmed recording, this step is unnecessary.
5. Press the COMP. REC button.

The system automatically performs the following functions:

Deck B:

- The tape rewinds to the beginning.
- Recording starts.

CD player:

- The player searches for the first track to be recorded, then enters the pause mode.
- CD play starts.

### Manual edit recording

Recording starts without rewinding the tape initially. Press the EDIT button to turn the "MANUAL" indication on before proceeding to step 5.

- To cancel this mode, press the button again. "MANUAL" disappears.
- After loading the cassette, the tape must be wound to the point where you would like to start recording.

"COMPU. REC", "▷", "▶" and "REC" appear on the display as recording begins.

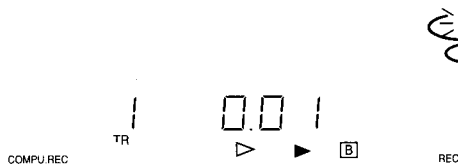

6. After deck B stops automatically, turn over the cassette and reinsert it.
  - If the tape ends while a track is still playing, the CD player enters the pause mode at the beginning of the track that was playing. This track will be recorded at the beginning of side B.
7. Press the COMP. REC button. Recording of side B starts automatically.

When the end of the tape (side B) is reached, the CD player and deck B stop automatically.

- If the last track on the CD plays completely before the end of the tape, disc play stops automatically. Deck B also stops.

Note:

- Recording starts automatically after 8 seconds, so the recording will not be interrupted by the leader tape at the beginning of tape.
- A 5-second blank space is automatically recorded at the end of each track.
- To stop computer recording at any time, press the ■ button on the CD player or deck. The CD player and deck B will stop.
- When CD computer recording is used, repeat play mode is cancelled automatically.

### Manual recording

1. Follow the steps 1 - 3 under "Computer recording" above.
  - If required, press the DISC SELECT button (DISC 1, DISC 2 or DISC 3) to select the disc, then press the ■ button. Select the track number to be recorded.
2. Press the REC PAUSE button. Deck B enters the record pause mode. "REC" appears and "▶" blinks on the display.
3. Press the ▶ button. "▶" remains lit and recording starts.
4. To stop recording, press the ■ button on the deck.

When the end of the tape is reached, the CD player and deck B stop automatically.

## RECORDING FROM THE TUNER OR VIDEO/ DVD INPUT

1. Load a blank cassette into deck B.
2. Tune in the radio station to be recorded, or play a video cassette, video disc or DVD.
3. Press the REC PAUSE button. Deck B enters the record pause mode.
4. Press the ▶ button. Recording starts.
5. Press the REC PAUSE button to temporarily stop recording. Press the ▶ button again to continue.
6. Press the ■ button to stop recording.

### When beat interference is heard

A high-pitched noise called "beat" is sometimes heard during the recording of radio broadcasts. If this occurs,

1. Press the MEMORY button.
2. While "PRESET" is blinking, press the ▶▶/▶▶| button to select "bc-1" or "bc-2". Select the setting that gives the best results.

# TAPE DUBBING (Deck A to B)

Load the cassette to be played back into deck A and a blank cassette into deck B.

## Computer dubbing

- Use the same length cassettes in both decks for the computer dubbing operation.

1. Select "TAPE" function.
2. Press the COMP. REC button.

The system performs the steps below and automatically starts deck A playback and deck B recording.

- 1) Deck A: Tape rewinds.
- 2) Deck B: Tape rewinds.
- 3) Deck B: Erases the first few seconds of the tape

### Manual edit dubbing

Dubbing starts without rewinding both tapes initially. Press the EDIT button to turn the "MANUAL" indication on before proceeding to step 2.

- To cancel this mode, press the button again. "MANUAL" disappears. After loading the cassettes, each tape must be wound to the point where you would like to start dubbing.

"A -> B DUB", "COMPU. REC", "▶", "A", "B" and "REC" appear on the display as dubbing begins.

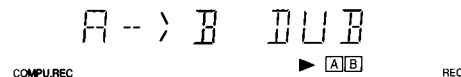

3. Press the ■ button (Deck section) to stop dubbing at any time.

## Manual dubbing

1. Select "TAPE" function.
2. Deck B: Locate the tape position where recording will begin.
3. Deck A: Locate the selection of the tape to be dubbed.
4. Press the REC PAUSE button. "REC" and "B" appear. "▶" blinks on the display.
5. Press the ▶ button. "A" appears and "▶" remains lit. Manual dubbing starts.
6. Press the ■ button to stop dubbing.

## Automatic stop during tape dubbing

If deck A or deck B stops automatically, the other deck will also stop.

# TIMER OPERATION

## Using the timer

Set the on and off times, function to be used and volume level. Operation will start with the selected function at the on time. The sound will be gradually increased from a no-sound level to the volume setting (fade-in). The power will be switched off at the off time. The timer will function every day unless it is released.

## Preparation

Note:

Make absolutely sure that the clock is set to the correct time before setting the timer.

- Select the function for timer operation and prepare the sources to be used.
  - If the function selected is tuner, tune in to the desired band and station.
- Adjust the volume level as desired.

## Operation

1. Press the TIMER button. The previous timer on time setting appears.

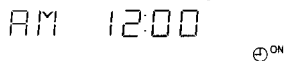

2. Press the MEMORY (or ADJUST) button within 10 seconds.

When using the main unit, use the MEMORY, ►►/►► and ◀◀/◀◀ buttons. When using the remote control, use the ADJUST, + and - TIME SET buttons.



3. Set the timer on time by pressing the ►►/►► or ◀◀/◀◀ (or + or - TIME SET) button, then press the MEMORY (or ADJUST) button (as described under "ADJUSTING THE CLOCK").

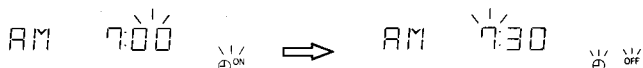

The timer off time setting appears.

4. Set the timer off time as described in step 3.

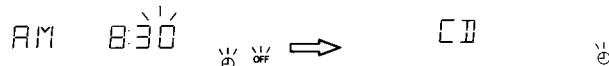

The previous timer mode setting (play: "⌚" or recording: "⌚ REC") and the current function appear.

5. Select the timer mode by pressing the ►►/►► or ◀◀/◀◀ (or + or - TIME SET) button.
  - "⌚ REC" and "⌚" blinks alternately. Select "⌚ REC" for unattended recording.
  - If you wish to change the function, press the function button to be changed.
6. Press the MEMORY (or ADJUST) button. The original display returns, then the timer operation standby mode is activated. "⌚" (or "⌚ REC") remains lit.
7. Press the ⏻/ON button to switch off the power.
  - "⌚" blinks during a timer controlled operation.
  - To switch off the power during a timer controlled operation, press the ⏻/ON button. The timer will be set in the standby mode.

## To check the timer settings

Press the TIMER button repeatedly. The timer settings are displayed in the following order:

On time → Off time → Timer mode/Function → Original display returns

To change the settings, press the TIMER button to select the setting to be changed, then press the MEMORY (or ADJUST) button so that the display blinks. Change the setting as explained above.

### To release the timer

After turning the power on, press the TIMER button, then press the ■ (or SET/CLEAR) button.

When using the main unit, use the ■ button (CD section).  
When using the remote control, use the SET/CLEAR button.

### To set the timer again with the same settings

1. Press the TIMER button, then press the ■ (or SET/CLEAR) button.
2. Press the ⏻/ON button to switch off the power.

#### Note:

- If the ■ (or SET/CLEAR) button is pressed while the timer is being set, the original display returns.
- The timer mode is released if a power failure occurs during timer controlled operation.
- The timer may not operate if a power failure occurs during timer operation standby mode.

### Using the sleep timer (Using the remote control)

The sleep timer automatically switches off the power after a preset time has elapsed. The volume will gradually be reduced (fade-out) during the 1-minute period before the unit turns off. There are 12 time periods available: 120, 110, 100, 90, 80, 70, 60, 50, 40, 30, 20, and 10 minutes.

Press the SLEEP button repeatedly to select the desired sleep time. "SLEEP" and the selected time blink on the display. After several seconds, the original display returns. "SLEEP" blinks.

### To check the remaining sleep time

Press the SLEEP button once. The remaining time is displayed. After several seconds, the original display returns.

### To release the sleep timer while in operation

Press the SLEEP button, then press the SET/CLEAR button. The timer is also released if the power is switched off.

## MAINTENANCE

### Cleaning the tape heads

To ensure continued high performance, use cotton swab to clean the heads, pinch rollers and capstans of the decks after about every 10 hours of use. If the dirt persists, soak the swab in a little methylated spirit or head cleaning fluid and then clean.

### Cleaning the unit

Clean the outside of the unit with a clean soft cloth, moistened with lukewarm water. Do not use benzene, thinner or alcohol since they will mar the finish of the surfaces.

