

## INSTRUCTION MANUAL

## Mini Component System

## DC-D5

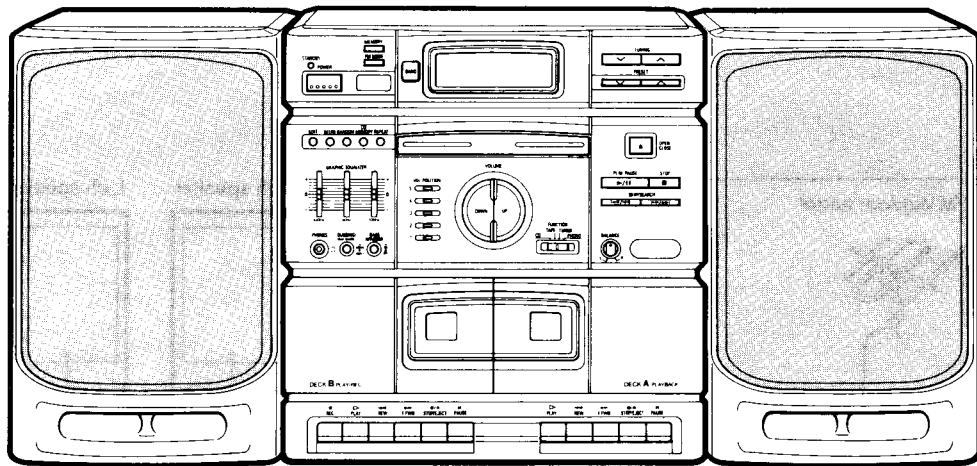

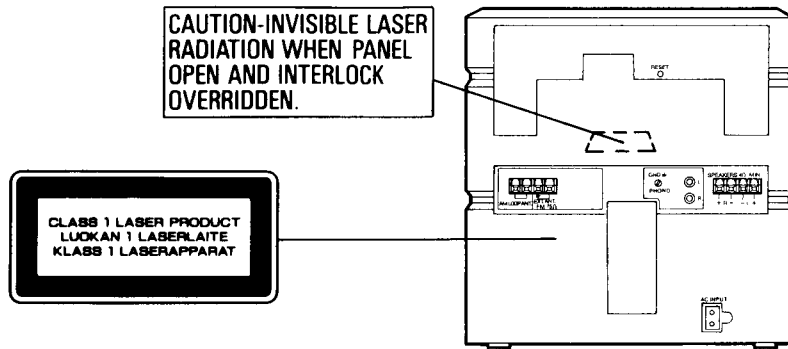

CAUTION - USE OF CONTROLS OR ADJUSTMENTS OR PERFORMANCE OF PROCEDURES OTHER THAN THOSE SPECIFIED IN THE OPERATING INSTRUCTIONS MAY RESULT IN HAZARDOUS RADIATION EXPOSURE.

THE COMPACT DISC PLAYER SHOULD NOT BE ADJUSTED OR REPAIRED BY ANYONE EXCEPT PROPERLY QUALIFIED PERSONNEL.

## PRECAUTIONS

- If water should enter the unit, electrical shock or malfunction may result. Always use it in a place where there is low humidity and little dust.
- Do not use where there are extremes of temperature (below 5°C or exceeding 35°C) or where direct sunlight may strike it.
- Because of the CD player's extremely low noise and wide dynamic range, there might be a tendency to set the volume on the amplifier unnecessarily high. Doing so may produce an excessively large output from the amplifier which could damage your speakers.
- Sudden changes in the ambient temperature may cause condensation to form on the optical lens inside the unit. If this happens, take out the disc, leave the unit with the disc tray extended for about 1 hour, and then proceed to operate.
- The system's speakers use powerful magnets. Do not place time-pieces, credit cards, cassette tapes or video tapes, etc. near the speakers.

## CONNECTIONS

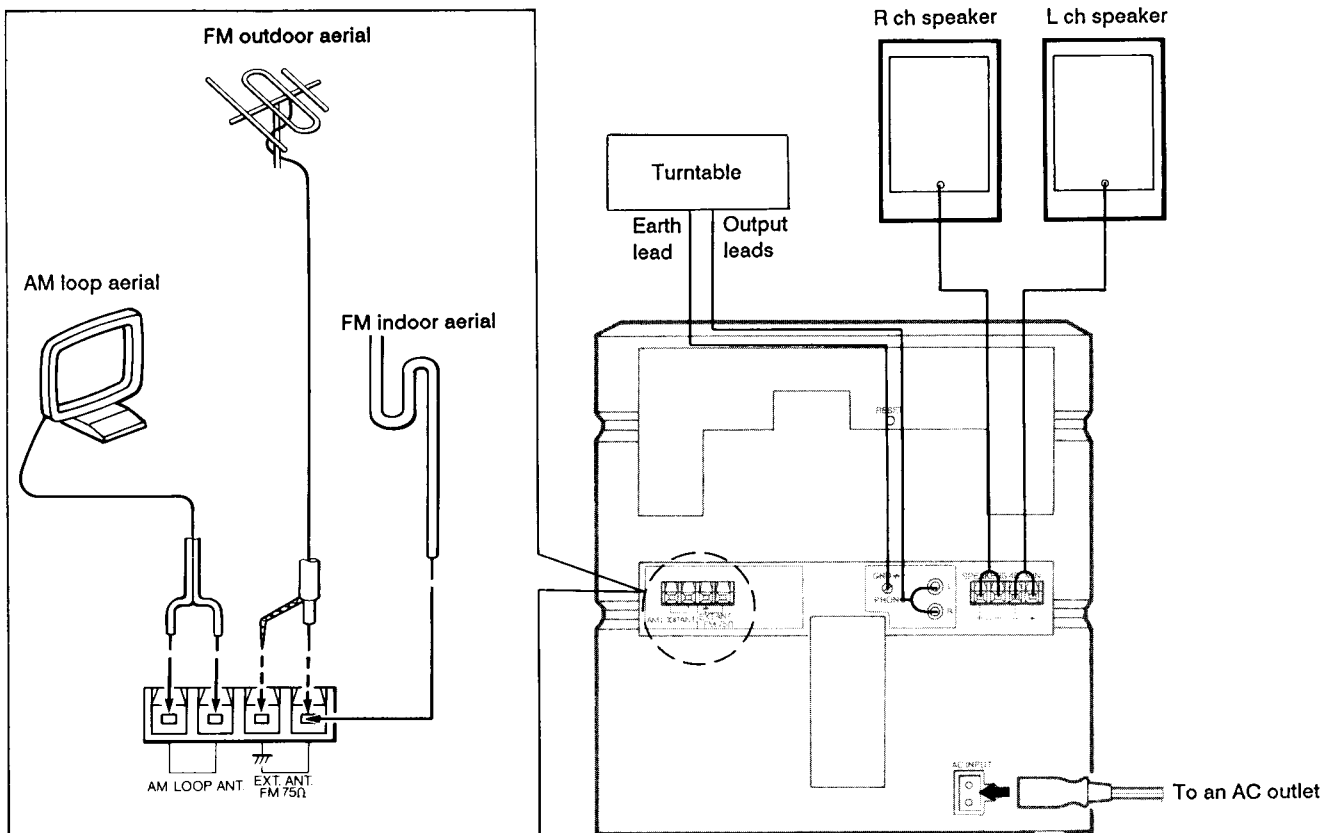

**Note:**

Do not connect the mains lead to an AC outlet until all connections have been made.

The system is not disconnected from the mains unless the mains lead is unplugged from the AC outlet.

**Speakers**

When connecting the speakers, make sure that (+) and (-) polarities are matched properly. Otherwise, the sound may appear to be lacking in the bass range and in stability.

Connect the speaker wire with the stripe to the red terminal (+) and the other wire to the black terminal (-).

**FM aerial**

The FM indoor aerial is sufficient to receive most local FM broadcasts and should be connected to the EXT. ANT. terminal. Extend the aerial wire as straight as possible and, while listening to the sound from the system, secure it in a position which yields minimal distortion and noise.

In fringe areas or where reception is distorted or noisy, an FM outdoor aerial (not supplied) should be connected instead of the indoor aerial. The terminals will accept 75-ohm coaxial cable. Consult your dealer.

**AM loop aerial**

Assemble the loop aerial as shown in figure.

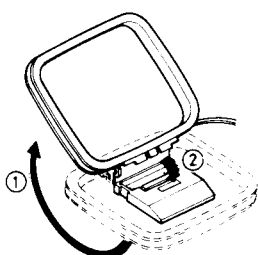

Unwind the aerial wires (about 2 turns), then connect them to the AM LOOP ANT. terminals. Place the loop aerial in a position which yields the best AM reception, or attach it to a wall or other surface as shown in figure.

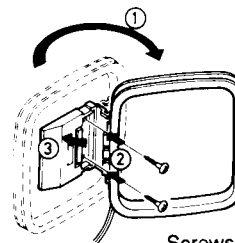

Screws (not supplied)

**Note:**

To minimize noise, the speaker, mains and any other leads should not come close to the FM indoor or outdoor aerial lead and AM loop aerial. Do not place the aerial leads close to the system.

**Turntable**

Connect the output leads and earth lead of a turntable (MM type) to the PHONO sockets and GND terminal of the unit respectively.

**Headphones**

Connect stereo headphones (not supplied) to the PHONES socket for monitoring or for private listening. The speakers are automatically disconnected when headphones are connected.

# CONTROLS

## Tuner section

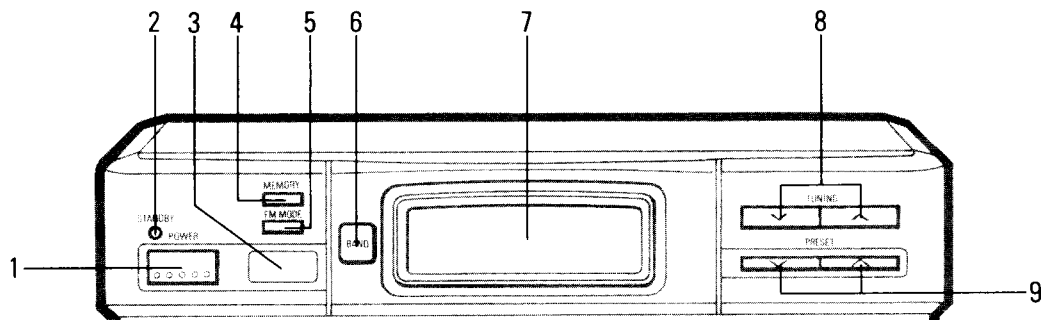

- |                                |                                    |
|--------------------------------|------------------------------------|
| 1. Power switch (POWER)        | 6. Band select switch (BAND)       |
| 2. Standby indicator (STANDBY) | 7. Display                         |
| 3. Remote sensor (IR)          | 8. Tuning switches (TUNING)        |
| 4. Memory switch (MEMORY)      | 9. Preset tuning switches (PRESET) |
| 5. FM mode switch (FM MODE)    |                                    |

## CD player/Amplifier section

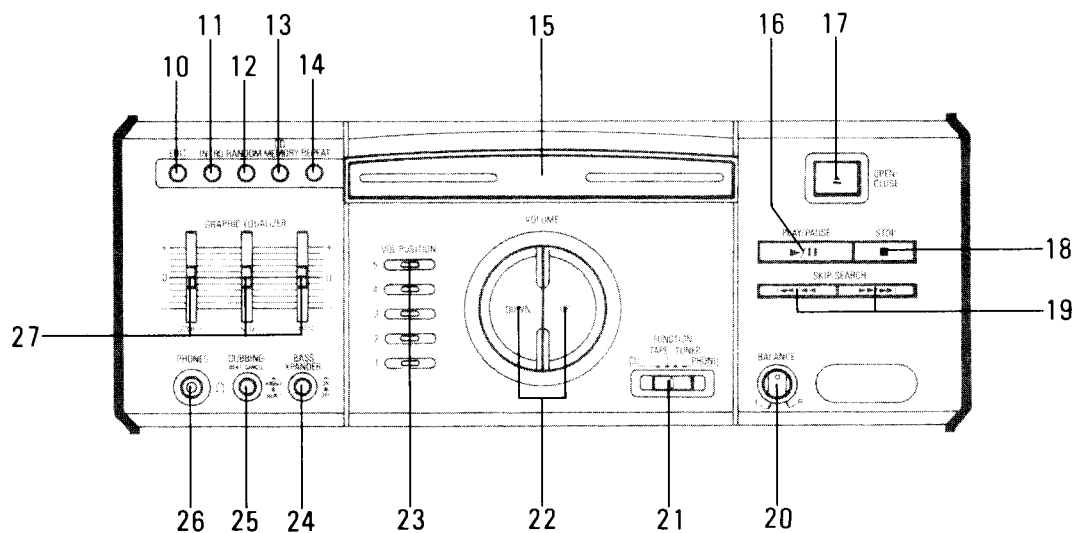

- |  |  |
|--|--|
| 10. Edit switch (EDIT)                       | 19. Skip/Search switches (SKIP/SEARCH)                     |
| 11. Introscan switch (INTRO)                 | 20. Balance control (BALANCE)                              |
| 12. Random play switch (RANDOM)              | 21. Function switch (FUNCTION)                             |
| 13. CD memory switch (CD MEMORY)             | 22. Volume controls (VOLUME)                               |
| 14. Repeat play switch (REPEAT)              | 23. Volume position indicators (VOL POSITION)              |
| 15. Disc tray                                | 24. Bass expander switch (BASSXPANDER)                     |
| 16. Play/Pause switch (PLAY/PAUSE)           | 25. Dubbing speed/Beat cancel switch (DUBBING/BEAT CANCEL) |
| 17. Disc tray open/close switch (OPEN/CLOSE) | 26. Headphones socket (PHONES)                             |
| 18. Stop switch (STOP)                       | 27. Graphic equalizer controls (GRAPHIC EQUALIZER)         |

## Cassette deck section

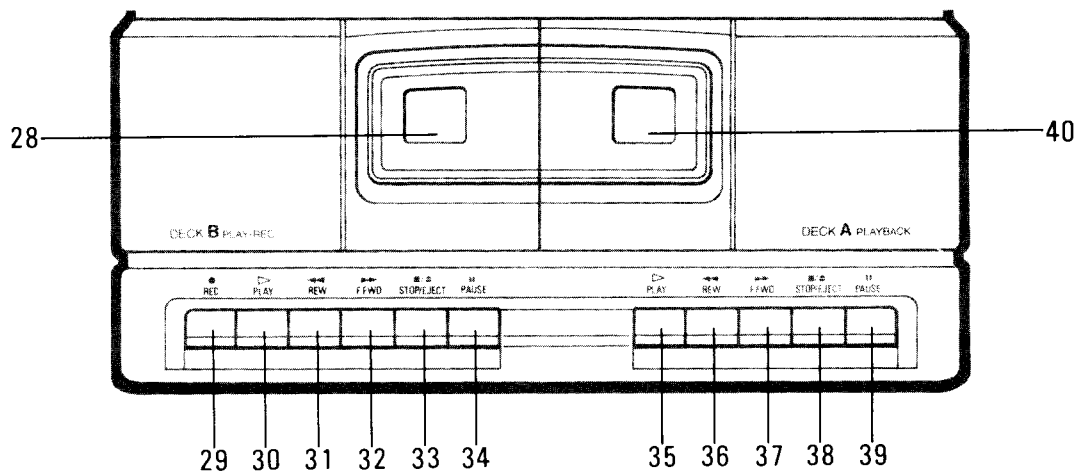

### DECK B

- 28. Cassette holder
- 29. Record button (REC)
- 30. Play button (PLAY)
- 31. Rewind button (REW)
- 32. Fast forward button (FFWD)
- 33. Stop/Eject button (STOP/EJECT)
- 34. Pause button (PAUSE)

### DECK A

- 35. Play button (PLAY)
- 36. Rewind button (REW)
- 37. Fast forward button (FFWD)
- 38. Stop/Eject button (STOP/EJECT)
- 39. Pause button (PAUSE)
- 40. Cassette holder

## REMOTE CONTROL

### Controls

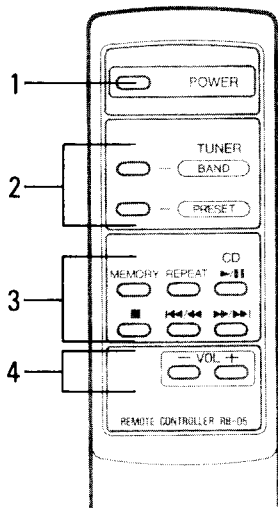

1. Power switch (POWER)
2. Tuner controls  
BAND: Band select switch  
PRESET: Preset tuning switch
3. CD player controls  
MEMORY: CD memory switch  
REPEAT: Repeat play switch  
▶/|| : Play/Pause switch  
■ : Stop switch  
◀◀/▶▶ : Skip/Search switches
4. Volume controls (VOL)

### Remote control range

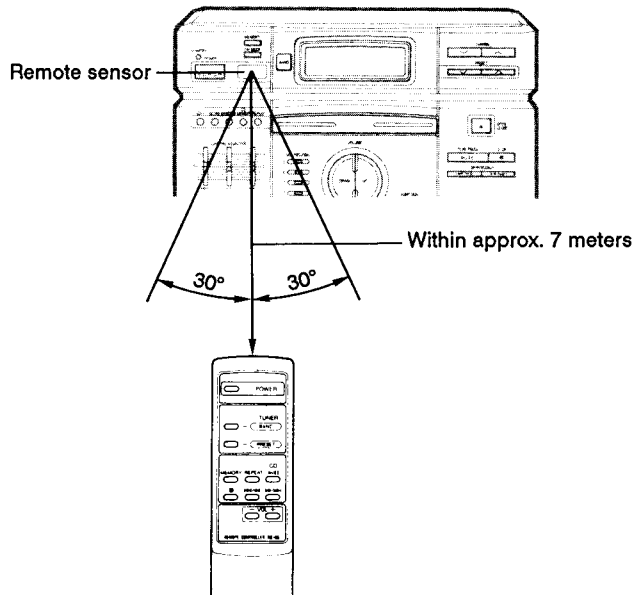

### Inserting batteries

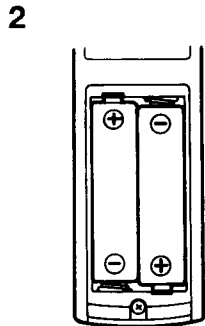
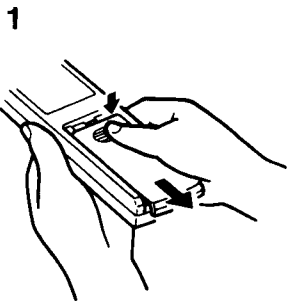

Two AA/SUM-3/R6 batteries  
(not supplied)

### Operation

By using the remote control, you can operate the system in the same way as with the controls on the main unit.

### Note:

Always remove batteries if the remote control is not to be used for a month or more. Batteries left in the unit may leak and cause damage.

# BEFORE OPERATION

## Turning the power on and off

Press the POWER switch. The STANDBY indicator goes out. "HELLO" appears on the display, then the function mode appears.

To turn off the power, press the POWER switch again. The STANDBY indicator lights.

- When the mains lead is connected to the AC outlet, the STANDBY indicator lights and the unit will respond to commands from the remote control.

## Selecting the function

Set the FUNCTION switch to the desired position.

- When the FUNCTION switch is moved from "CD" to another position, CD play stops automatically.

## Adjusting the volume

Press the UP or DOWN VOLUME control, or "+" or "-" VOL control on the remote control.

## Volume position indicators

The VOL POSITION indicators show the relative volume position.

## Adjusting the left/right speaker balance

Use the BALANCE control to adjust the left/right speaker balance.

## Bass expander system

Press the BASSXPANDER switch to ON to enhance the bass sound.

## Adjusting the sound quality

The GRAPHIC EQUALIZER controls (300Hz/1kHz/10kHz) allow the sound to be tailored to individual musical preferences or to fit the acoustics of the room. Moving the control will adjust the sound level in a narrow range of musical frequencies.

## WHAT TO DO IF ...

If the operation of the unit or display is not normal or when all the memory contents are to be cleared, disconnect the mains lead from the AC outlet, then press the RESET button (rear of the unit) for 20 seconds or more.

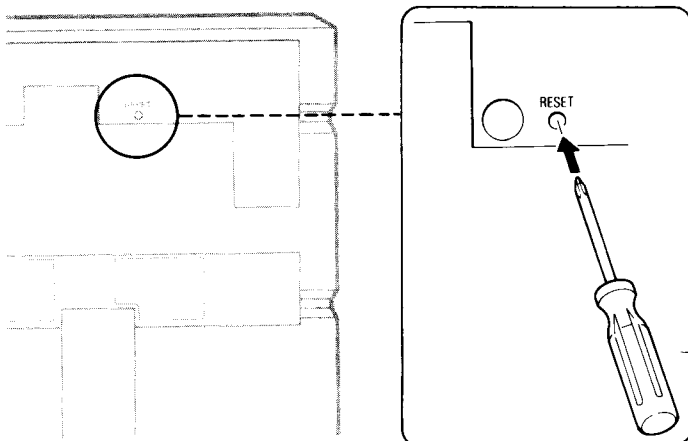

# CD PLAY

Use compact discs bearing the symbol shown below. In addition to conventional 12 cm CDs, this system can be used to play 8 cm CDs without an adapter.



1. Set the FUNCTION switch to CD. "NO DISC" appears on the display.
2. Press the OPEN/CLOSE switch.  
The disc tray slides out and "OPEN" appears on the display.
3. Place the disc with the label facing up on the disc tray.

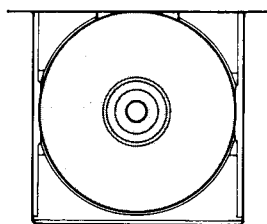

For 12 cm CD

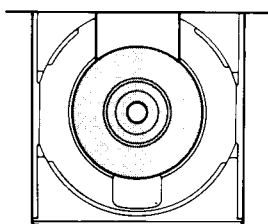

For 8 cm CD

4. Press the OPEN/CLOSE switch again to close the disc tray.  
The total number of tracks and total play time on the disc are displayed.
5. Press the PLAY/PAUSE switch.

TRACK 1 0.01 ▶

"▶" appears, and play starts from the first track. The track number and elapsed play time for the current track are displayed.

- If you press the PLAY/PAUSE switch while the tray is still open, it will close, and play will begin automatically.
  - To start play from the desired track, select the track by using the SKIP/SEARCH switches, then press the PLAY/PAUSE switch.
6. Press the STOP switch to end disc play.  
The total number of tracks and total play time are displayed.  
When the last track has been played, the player stops automatically.
  - When the OPEN/CLOSE switch is pressed during play, play will stop and the disc tray will slide out.

## Notes on handling compact discs

- Do not expose the disc to direct sunlight, high humidity or high temperatures for extended periods of time.
- Discs should be returned to their cases after use.
- Do not apply paper or write anything on the disc surface.
- Handle the disc by its edge. Do not touch the playing surface (glossy side).
- Fingerprints and dust should be carefully wiped off the playing surface of the disc with a soft cloth.  
Wipe in a straight motion from the centre to the outside of the disc.
- Never use chemicals such as record cleaning sprays, antistatic spray or fluids, benzene or thinner to clean compact discs.

## Temporarily stopping play

Press the PLAY/PAUSE switch. "▶" blinks on the display. To resume play, press the switch again.

## Skip play

To skip to track 6 while track 3 is playing, press the ▶▶ / ▶▶▶ SKIP/SEARCH switch repeatedly until "6" appears in TRACK on the display. To skip back to track 3 while track 6 is playing, press the ◀◀ / ◀◀◀ SKIP/SEARCH switch repeatedly until "3" appears.

## Search (forward/reverse)

If the ▶▶ / ▶▶▶ or ◀◀ / ◀◀◀ SKIP/SEARCH switch is pressed during play, the player will search at high speed in the forward or reverse direction while the switch is being pressed. When the switch is released, normal play will continue.

## Intros can

Press the INTRO switch to play the first 10 seconds of each track. "INTRO" appears on the display.

- Press the INTRO switch again to return to normal play.
- If the INTRO switch is pressed during normal play, intros can will start with the next track on the disc.

## Random play

Press the RANDOM switch to begin random play. The player will automatically select and play tracks on the disc at random. "RANDOM" appears on the display.

- If the RANDOM switch is pressed during random play, the player will select the next random track.

## Random introscan play

Press the RANDOM switch, then the INTRO switch, to play the first 10 seconds of each track at random.

## Repeat play

Press the REPEAT switch during play. The player will play all the tracks, all the programmed tracks or all the random play tracks repeatedly. "REPEAT" appears on the display.

To cancel repeat play, press the REPEAT switch again. "REPEAT" disappears.

## PROGRAMMED PLAY

Up to 24 selections on a disc can be programmed for play in any order.

- To begin the programming procedure, select "CD" function first.
- The tracks are programmed in the stop mode.
- The same track can be programmed more than once.

Example:

To programme tracks 5, 2, 6 and 10

1. Press the CD MEMORY switch.

PROG. TRACK 1 Pr. 1

2. Select track 5 by pressing the ►► / ►►► SKIP/SEARCH switch 4 times.

PROG. TRACK 5 Pr. 1

3. Press the CD MEMORY switch. "PROG." remains lit.
4. Select track 2 by pressing the ◀◀ / ◀◀◀ SKIP/SEARCH switch 3 times.

PROG. TRACK 2 Pr. 2

5. Press the CD MEMORY switch. "PROG." remains lit.
6. The remaining tracks are programmed in the same way.
7. Press the PLAY/PAUSE switch to start play.

PROG. TRACK 5 0.01 ▶

When all programmed selections have played, the player stops automatically. The total programmed time appears.

- The programme contents are retained in memory.
- Any attempt to programme more than 24 selections will result in "FULL" being displayed and discontinuation of the programming.
- The programme is cleared in the following cases:
  - When the STOP switch is pressed in the stop mode
  - When the EDIT switch is pressed in the stop mode
  - When the OPEN/CLOSE switch is pressed

## Checking the programme

Each time the CD MEMORY switch is pressed in the stop mode, the programmed details sequentially appear on the display.

## Changing a programme

To add a new selection to a programme:

1. In the stop mode, press the CD MEMORY switch repeatedly until "----" is displayed.
2. Select a track number as explained above.

To change a selection:

1. In the stop mode, press the CD MEMORY switch repeatedly until the selection to be replaced is displayed.
2. Select a track number as explained above.

Note:

Programmed details cannot be partially deleted or inserted.

# LISTENING TO TAPES

Deck A is for playback only; deck B is for both playback and recording. Do not turn the unit off while the tape is running. Otherwise, the pinch roller may be damaged.

1. Set the FUNCTION switch to TAPE. "TA" appears on the display.
2. Press the STOP/EJECT button to open the cassette holder.
3. Load the cassette(s).

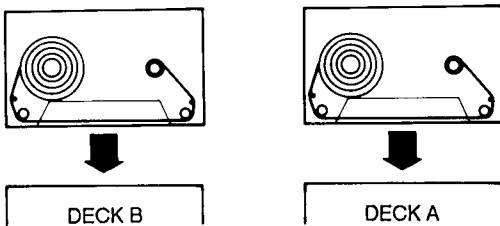

After the cassette has been loaded, push the cassette holder back into position.

4. Press the PLAY button (deck A or deck B) to begin playback.
  5. Press the STOP/EJECT button to stop playback at any time. Press it again to remove the cassette.
- When the end of the tape has been reached, automatic stop will be activated.

## Pause

Press the PAUSE button to temporarily stop playback or recording. Press it again to resume operation.

## Fast forward and rewind

Press the FFWD or REW button.

When the tape has been wound to the end, the deck stops automatically.

Note:

While playing or recording, do not press the FFWD or REW button of the other deck, or the sound quality may deteriorate.

## Continuous playback (From deck A to deck B)

1. Press the PLAY button of deck A. Deck A playback will begin.
  2. Press the PAUSE button of deck B.
  3. Press the PLAY button of deck B. Deck B enters the pause mode.
- When the tape automatically stops on deck A, deck B playback will begin.
- When the end of the tape has been reached on deck B, automatic stop will be activated.

# LISTENING TO THE RADIO

## Memory operation

This unit enables 12 stations FM1, FM2 and AM bands to be preset in the memory.

1. Set the FUNCTION switch to TUNER.
2. Select the band (FM1, FM2 or AM) by pressing the BAND switch.
3. Press the  $\nabla$  or  $\blacktriangle$  TUNING switch continuously until you are close to the desired frequency, then press it briefly until the desired frequency is displayed. Each time the switch is pressed, the frequency changes in 0.05 MHz steps for FM and 9 kHz steps for AM.
4. Press the MEMORY switch. "PROG." blinks.

PROG. FM1 103.25 MHz

5. Select the required preset number by pressing the  $\nabla$  or  $\blacktriangle$  PRESET switch.

PROG. P09 FM1 103.25 MHz

6. Press the MEMORY switch to preset the station. "PROG." disappears.
  - If the next step is not taken within 10 seconds in steps 4 - 6, "PROG." disappears and the memory operation is cancelled. Press the MEMORY switch to continue.

7. Repeat steps 2 - 6, to add more preset stations.

- If a new station is programmed into a band and preset number already containing a programmed station, the previously programmed station will be cleared.
- The preset stations will be held in memory even if the unit is turned off. If the memory contents are lost due to a power failure or other condition, programme the stations again.

## Listening to the preset station

1. Select "TUNER".
2. Select the band.
3. Select the desired preset number by pressing the  $\nabla$  or  $\blacktriangle$  PRESET switch.

- For receiving an FM stereo broadcast, make sure that "MONO" is not displayed. If "MONO" appears, press the FM MODE switch to turn the "MONO" indication off. "STEREO" appears when an FM stereo broadcast is received.
- If the signals from an FM stereo station are weak and reception is poor, press the FM MODE switch to change to monaural reception. ("STEREO" is replaced by "MONO" in the display.)

## Changing the reception frequencies

It is not necessary to perform this procedure in the Australia.

1. Select the band to be changed.
2. Turn the power off.
3. While pressing the BAND button, press the POWER button.

AM: 520 - 1710 kHz (10 kHz steps)  $\longleftrightarrow$  522 - 1710 kHz (9 kHz steps)

# LISTENING TO RECORDS

1. Set the FUNCTION switch to PHONO. "PH" appears on the display.
2. Follow the instructions supplied with the turntable.

# RECORDING FROM THE TUNER OR PHONO INPUT

Recording copyright material without permission of the copyright owners is usually an infringement. If you wish to re-record copyright material, permission from the copyright owner is necessary. SANYO does not approve of, and cannot be held responsible for, any unlawful use of this machine.

## Accidental erasure prevention tabs (for protecting valuable recordings)

Accidental erasure can be prevented by breaking out the tabs on the end of the cassette tape (where the tape is not exposed) using a screwdriver or similar implement.

If a tab is broken out in error and you wish to re-record the tape, simply block the tab hole using adhesive tape and the tape can be used for recording again.

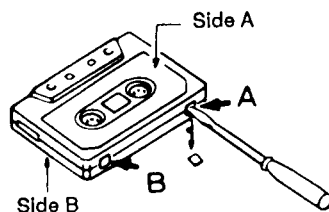

Break out tab A for side A.  
Break out tab B for side B.

Use deck B for recording.

1. Tune in the radio station to be recorded or play a record.
2. Press the STOP/EJECT button and load the cassette for recording.
3. Press the REC button to start recording. The PLAY button is engaged simultaneously.
4. Press the STOP/EJECT button to stop recording. When the end of the tape has been reached, automatic stop will be activated.

## When beat interference is heard

A high-pitched noise called "beat" is sometimes heard during the recording of radio broadcasts.

In cases like this, set the DUBBING/BEAT CANCEL switch to the position that reduces the level of the beat noise.



# RECORDING COMPACT DISCS

## EDIT RECORDING

The following edit recording operations can be performed.

- Time edit recording
- Programme edit recording
- Backward skip edit recording

Note:

- CD play starts automatically after 8 seconds, so the recording will not be interrupted by the leader tape at the beginning of sides A and B.
- A short blank space is automatically recorded at the end of each track.
- The highest track number which can be edited is 24.

## Preparations

Set the FUNCTION switch to CD, then load a disc into the CD player.

## Time edit recording

The tracks that will fit within a selected time period are automatically programmed for recording on sides A and B of the tape. (The tracks are edited so that the remaining time on the tape is reduced to a minimum).

Example: To record onto a 50-minute tape

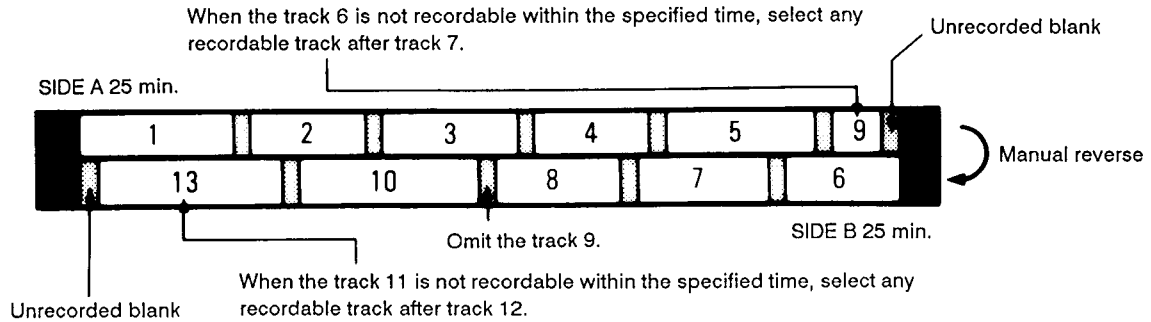

1. Press the EDIT switch to select the recording tape length. "C-46" appears on the display.
  - Each time the EDIT switch is pressed, the tape length display changes in the following sequence:  
C-46 -- C-54 -- C-60 -- C-74 -- C-90 -- C- ---- (Released) -- C-46 -- . . .
  - To set the desired tape length up to C-99, use the SKIP/SEARCH switches.
  - To set "C-50", select "C-46", then press the ►► / ►►► SKIP/SEARCH switch 4 times. "C-50" appears on the display.
2. Load a C-50 cassette into deck B to record side A.
3. Press the REC button of the deck. Deck B enters the record pause mode.
4. Press the PLAY/PAUSE switch of the CD player.
  - The total play time for side A is displayed.
  - The total play time for side B is displayed.

- Recording starts automatically from track 1.

PROG. TRACK 1 0.01 TIME EDIT SIDE A ►

When the tracks to be recorded onto side A have been played, the player enters the pause mode at the beginning of the first track to be recorded onto side B.

5. After the deck B stops automatically, turn over the cassette and reinsert it.
6. Press the REC button. Recording of side B starts automatically.

When the last track has been played, disc play stops automatically. The deck will continue recording to the end of the tape.

- To stop edit recording at any time, press the STOP switch of the CD player, then press the STOP/EJECT button of the deck B.
- The edit mode remains operational when recording ends. To cancel the edit mode, press the STOP switch of the CD player.

## Programme edit recording

The desired selections can be rearranged and recorded on the tape within a designated tape length.

Example: To record onto a 46-minute tape

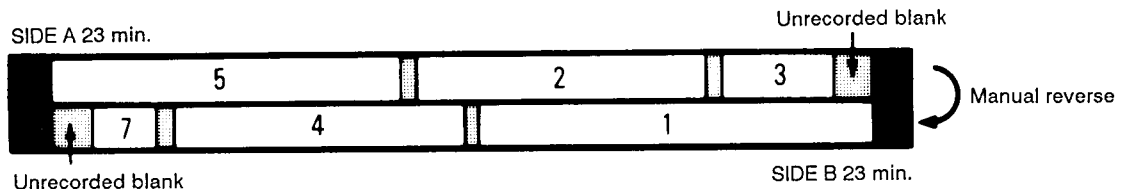

1. Press the EDIT switch until "C-46" appears.
2. Press the CD MEMORY switch.

PROG. TRACK 1 -11.51 EDIT SIDE A

The remaining time on side A is shown on the time display.

3. Select the track to be recorded by using the SKIP/SEARCH switches.

PROG. TRACK 5 -13.00 EDIT SIDE A

4. Press the CD MEMORY switch. "PROG." remains lit.

5. Repeat steps 3 - 4 to programme the tracks to be recorded onto side A.
  - If a track exceeding the remaining time on side A is selected, its play time blinks on the display. When the CD MEMORY switch is pressed, "SIDE A" disappears and "SIDE B" appears. The remaining time on side B appears on the display. This and subsequent tracks are recorded on side B.
6. Repeat steps 3 - 4 to programme the tracks to be recorded onto side B.
  - If a track exceeding the remaining time on side B is programmed, "Err" will appear on the display for 4 seconds.

7. Load a C-46 cassette into deck B to record side A.
8. Press the REC button.
9. Press the PLAY/PAUSE switch.
  - The total play time for side A is displayed.
  - The total play time for side B is displayed.

- Recording starts automatically from the first programmed track.

PROG. TRACK 5 0.01 EDIT SIDE A ▶

10. Follow steps 5 - 6 of "Time edit recording".

## Backward skip edit recording

This type of recording is the easiest to perform and the tape length setting is not required.

Example:

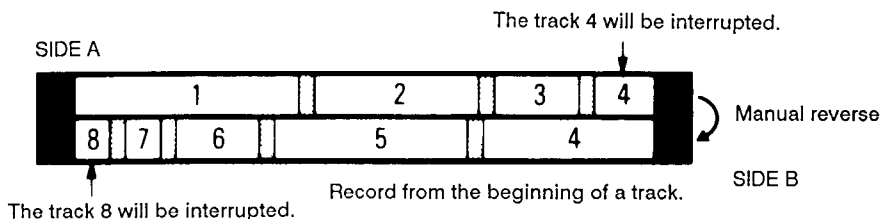

1. Press the EDIT switch until "C - -" appears.
2. Load a cassette.
3. Press the REC button.
4. Press the PLAY/PAUSE switch. Recording starts on side A.

5. Follow steps 5 - 6 of "Time edit recording".

- When the tape stops automatically at the end of side B, CD play also stops.

## MANUAL RECORDING

1. Set the FUNCTION switch to CD.
2. Load a disc and cassette.
  - For programmed recording, programme the material in advance (as described under "PROGRAMMED PLAY").

3. Press the REC button. (Deck B enters the record pause mode.)
4. Press the PLAY/PAUSE switch. Recording starts.

## TAPE DUBBING (DECK A to DECK B)

1. Load the playback cassette into deck A and a blank cassette into deck B.
2. Set the FUNCTION switch to TAPE.
3. Set the cassette in deck A to the point where recording will begin.
4. Select the dubbing speed with the DUBBING/BEAT CANCEL switch.
  - NOR:  
For dubbing while monitoring at normal speed.
  - HIGH:  
For dubbing the tape at high speed (twice normal speed).
5. Press the PAUSE button of deck B.
6. Press the REC button of deck B.

7. Press the PLAY button of deck A to start dubbing.
8. To stop dubbing, press both STOP/EJECT buttons.

### Automatic stop during dubbing

When deck A tape is longer than deck B tape:

When deck B stops automatically, deck A continues playback mode at normal speed.

When deck B tape is longer than deck A tape:

When deck A stops automatically, deck B erases the tape to the end.

- Do not change the dubbing speed during the dubbing operation.

# MAINTENANCE

## Cleaning the decks A and B heads

To ensure playback and recording with good-quality sound, use cotton swab to clean the heads, pinch rollers and capstans of the decks after about every 10 hours of use.

If the dirt persists, soak the swab in a little methylated spirit or head cleaning fluid and then clean.

## Main unit

Use a soft cloth to remove dirt on the main unit.

If the dirt persists, dip a soft cloth into a diluted solution of neutral detergent, wring it out, wipe away the dirt, and then take up any moisture with a dry cloth.

Do not use benzine, thinners or alcohol since they will mar the finish of the surfaces.

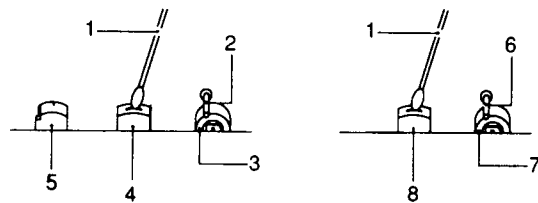

1. Cotton swab
- 2, 6. Capstan
- 3, 7. Pinch roller
5. Erase head in DECK B
- 4, 8. Record/Play head (Play head in DECK A)

# SPECIFICATIONS

## Tuner section

Reception frequency:

FM: 87.5 - 108 MHz

AM: 522 - 1710 kHz

## CD player section

Channels:

2-channel stereo

Sampling frequency:

44.1 kHz

Pick-up:

Optical 3-beam semiconductor laser

Frequency response:

20 Hz to 20 kHz

Wow/flutter:

Below measurable limits

## Cassette deck section

Track system:

4-track, 2-channel stereo

Frequency response:

80 Hz to 13.5 kHz

Signal-to-noise ratio:

50 dB

Wow/flutter:

0.15% (WRMS)

Fast forward/rewind time:

Approx. 110 sec. (C-60)

## Amplifier section

Output power:

5 W x 2 (at 4 ohms, 10% distortion)

Graphic equalizer:

±10 dB (300Hz, 1kHz, 10kHz)

Inputs

PHONO: 2.5 mV/50k ohms

Outputs

SPEAKERS: 4 ohms

PHONES: 8 - 32 ohms

Power requirements:

AC 230 - 240 V, 50 Hz

Power consumption:

50 W

Dimensions:

270(W) x 285(H) x 186(D) mm

Weight:

3.8 kg

## Speaker systems

Type:

2 way bass reflex

Unit used:

Woofers: 12 cm cone type

Tweeter: piezoelectric

Maximum power-handling capacity:

10 W (peak)

Nominal impedance:

4 ohms

Dimensions:

180(W) x 285(H) x 191(D) mm

Weight:

1.4 kg (per speaker)

Specifications subject to change without notice.

