

SANYO

INSTRUCTION MANUAL

DC-DA2000

Micro Component System

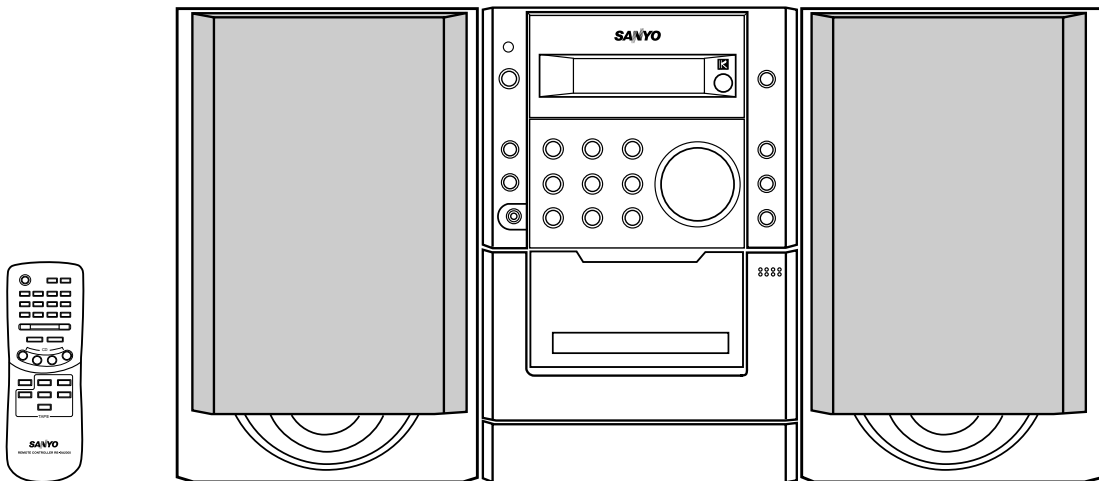

PRECAUTIONS

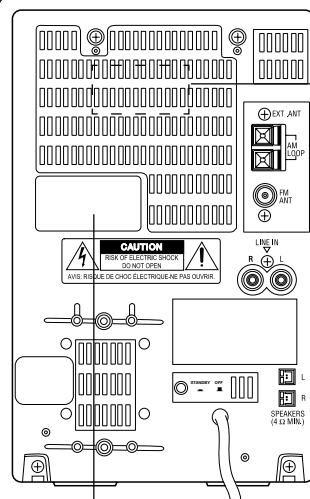

CAUTION-INVISIBLE LASER RADIATION WHEN OPEN AND INTERLOCKS DEFEATED. AVOID EXPOSURE TO BEAM.	
ADVARSEL-USYNLIG LASER STRÅLING VED ÅBNING, NÅR SIKKERHEDSAFBRYDERE ER UDE AF FUNKTION, UNDGÅ UDSÆTTELSE FOR STRÅLING.	
VARNING-OSYNLIG LASER STRÅLNING NÅR DENNA DEL ÄR ÖPPNAD OCH SPÄRR ÄR URKOPPLAD. STRÅLEN ÄR FARLIG.	
VORSICHT! -UNSIHTBARE LASERSTRAHLUNG TRITTS AUS, WENN DECKEL GEÖFFNET UND ENN SICHERHEITVERRIEGELUNG ÜBERBRÜCKT IST. NICHT, DEM STRAHL AUSSETZEN.	
VARO !-Avattaessa ja suojauslaitus ohitettaessa olet alttiina näkymättömälle lasersäteilylle. Älä katso säteeseen.	

**CLASS 1 LASER PRODUCT
LUOKAN 1 LASERLAITE
KLASS 1 LASERAPPARAT**

CAUTION - USE OF CONTROLS OR ADJUSTMENTS OR PERFORMANCE OF PROCEDURES OTHER THAN THOSE SPECIFIED IN THE OPERATING INSTRUCTIONS MAY RESULT IN HAZARDOUS RADIATION EXPOSURE. THIS PRODUCT SHOULD NOT BE ADJUSTED OR REPAIRED BY ANYONE EXCEPT PROPERLY QUALIFIED PERSONNEL.

- The apparatus shall not be exposed to dripping or splashing.
- No objects filled with liquids, such as vases, shall be placed on the apparatus.
- Do not use where there are extremes of temperature (below 5°C or exceeding 35°C) or where direct sunlight may strike it.
- Because of the CD player's extremely low noise and wide dynamic range, there might be a tendency to set the volume on the amplifier unnecessarily high. Doing so may produce an excessively large output from the amplifier which could damage your speakers.
- Sudden changes in the ambient temperature may cause condensation to form on the optical lens inside the unit. If this happens, take out the disc, leave the unit for about 1 hour, and then proceed to operate.
- The system's speakers use powerful magnets. Do not place timepieces, credit cards, cassette tapes or video tapes, etc. near the speakers.
- Do not install this equipment in a confined space, such as a book case or built in cabinet.

CONNECTIONS

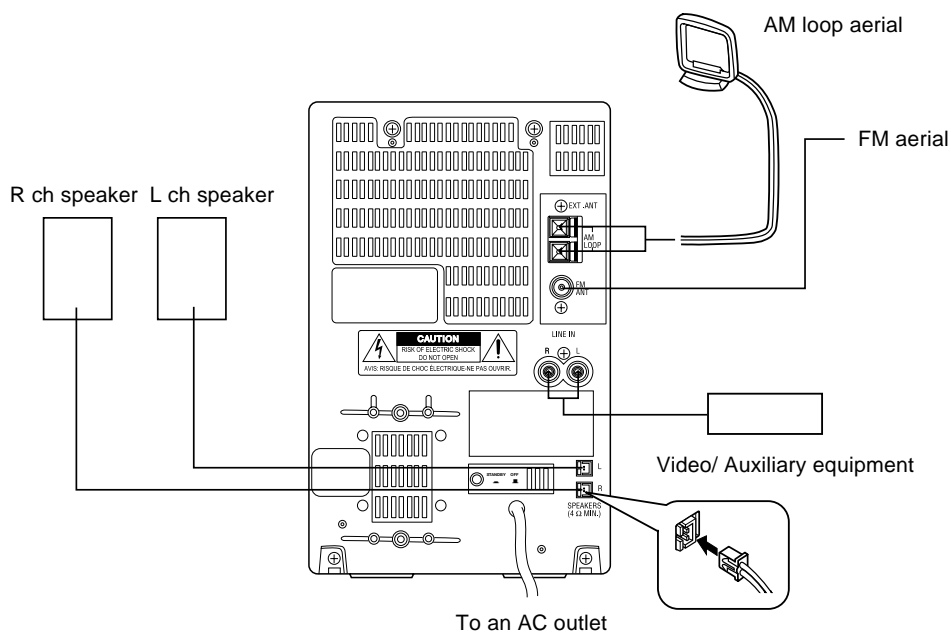

Note:

- Do not connect the mains lead to an AC outlet until all connections have been made.
- The system is not completely disconnected from the mains when the power button is set to the  position.

Speakers

Connect the connector of the left speaker lead to the "L" SPEAKERS socket and the connector of the right speaker lead to the "R" socket.

If you have difficulty inserting the speaker lead connector, turn it over and reinsert it.

FM aerial

FM indoor aerial is sufficient to receive broadcasts. Extend the aerial wire as straight as possible and, while listening to the sound from the system, secure it in a position which yields minimal distortion and noise.

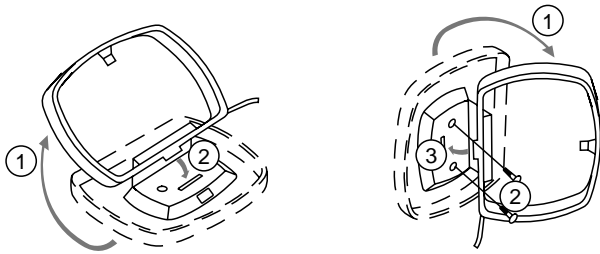

Screws (not supplied)

AM Loop aerial

Assemble the loop aerial as shown in figure. Unwind the aerial wires, then connect them to the AM LOOP terminals. Place the loop aerial in a position which yields the best AM reception, or attach it to a wall or other surface as shown in figure.

Note:

To minimize noise, the speaker, mains and any other leads should not come close to the indoor or external aerial lead and AM loop aerial. Do not place the aerial leads close to the system.

Video/Auxiliary equipment

Connect audio leads (not supplied) from the audio output sockets of a video/auxiliary equipment to the LINE IN sockets.

Headphones

Connect stereo headphones (not supplied) to the PHONES socket for monitoring or for private listening. The speakers are automatically disconnected when headphones are connected.

CONTROLS

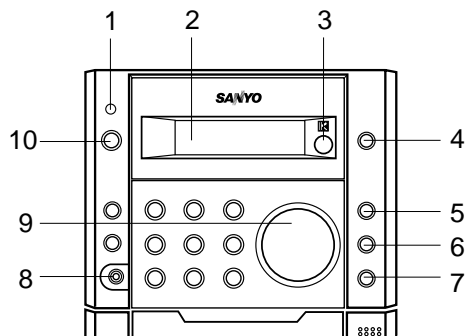

General

1. Standby indicator (STANDBY)
2. Display
3. Remote sensor (IR)
4. Function button (FUNCTION)
5. Bass expander button (BASS)
6. Sound preset button (SOUND PRESET)
7. Surround button (SURROUND)
8. Headphones socket (PHONES)
9. Volume control (VOLUME)
10. Power button (⏻/ON)

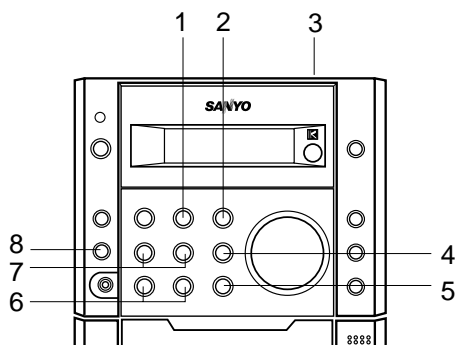

CD player/Tuner

1. Repeat play button (REPEAT)
2. Play/Pause button (CD/▶/||)
3. CD Compartment lid
4. Stop/Clear button (□)
5. Tuner function/Band select button (TUNER/BAND)
6. Preset tuning buttons (PRESET -, +)
7. Skip/Search/Tuning buttons (TUNING -, +, ◀◀, ▶▶)
8. FM mode button (FM MODE)

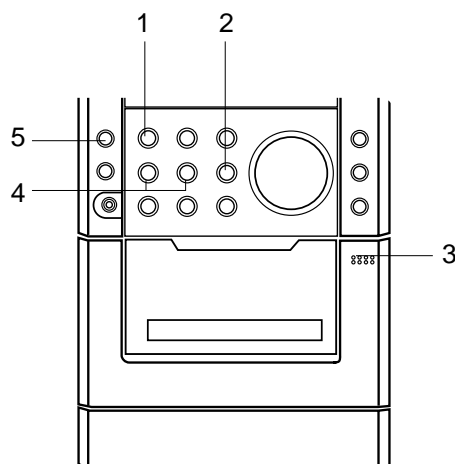

Cassette deck

1. Play button (TAPE)
2. Stop button (□)
3. Cassette holder
4. Fast forward/ Rewind buttons (▶▶, ◀◀)
5. Record/Record pause button (●/||)

REMOTE CONTROL

Controls

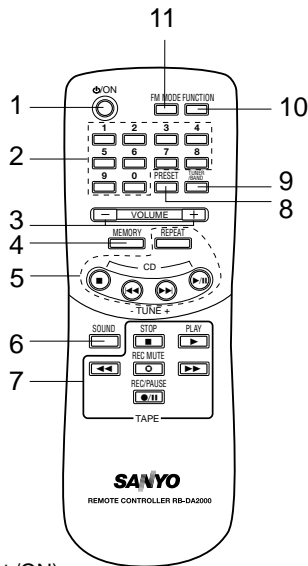

1. Power button (⏻/ON)
2. Number buttons (1-9, 0)
3. Volume buttons (VOLUME +, -)
4. Memory button (MEMORY)
5. CD player controls
REPEAT: Repeat button
■: Stop button
◀◀, ▶▶: Skip/Search buttons (These buttons can also be use as tuning buttons)
▶▶/||: Play/Pause button
6. Sound preset button (SOUND)
7. Cassette deck controls :
■: Stop button
▶: play button
◀◀: Rewind button
▶▶: Fast forward button
○: Record muting button
●/||: Record/Record pause button
8. Preset button (PRESET)
9. Tuner function/Band select button (TUNER/BAND)
10. Function button (FUNCTION)
11. FM mode button (FM MODE)

Number buttons (1-9, 0)

These buttons are used to select the track numbers on a disc or preset radio stations.

If the function is "CD", the buttons select the track numbers on a disc. If the function is "TUNER", the buttons select preset radio stations.

With any other function, the buttons will not function.

- Two buttons must always be pressed.

Example:

To select No. 3, press 0, then 3.

To select No. 10, press 1, then 0.

To select No. 25, press 2, then 5.

Inserting batteries

1

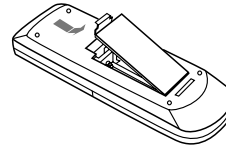

2

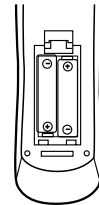

Two R03/HP16 batteries
(not supplied)

Note:

Always remove batteries if the remote control is not to be used for a month or more. Batteries left in the unit may leak and cause damage.

Remote control range

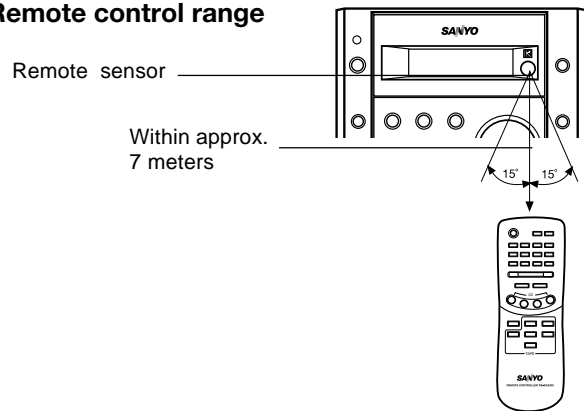

GENERAL OPERATION

Turning the power on and off

Before use, be sure to press the AC power button (rear of the unit) to "STANDBY". If the unit is not to be used for a long period of time, press the button again to "OFF".

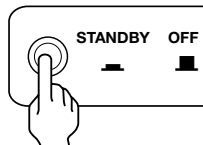

To turn the power on, press the ⏻/ON button on the front panel, the STANDBY indicator goes out, and the display lights.

To turn the power off, press the ⏻/ON again, the STANDBY indicator lights and the display goes out.

Note:

- Do not connect the mains lead to an AC outlet until all connections have been made.
- The system is not completely disconnected from the mains when the ⏻/ON button is set to the ⏻ position.

Selecting the function

Press the FUNCTION button to select the desired function as follows display shows.

Cd → TAPE → TU → LinE → Cd → ...

The function is automatically selected when CD play or tape playback is started or when the TUNER/BAND button has been pressed (except during recording).

- When the function selection is changed, CD play or tape playback is automatically stopped.

Adjusting the volume

Turn the VOLUME control, (or press the + or - VOLUME button on the remote control). The volume level appears on the display. (VOL 0 ~ VOL 40)

Surround sound button

Press the SURROUND button, "SURR" appears on the display and a 3 dimensional sound effect is created.

Bass expander button

Press the BASS button to enhance the bass sound. "BASS" appears on the display.

Selecting the sound mode

Press the SOUND PRESET button to select the sound mode matching the music to be listened to.

- POP: Pops, etc.
- ROCK: Rock music, etc.
- JAZZ: Jazz, etc.
- CLASSIC: Classical music, etc.

WHAT TO DO IF ...

If the operation of the unit or display is not normal,

1. Disconnect the mains lead.
2. Press the ▶/|| button on the unit for at least 60 seconds.
3. Connect the mains lead.
4. Operate the unit.

CD PLAY

Use compact discs bearing the symbol shown. In addition to conventional 12 cm CDs, this system can be used to play 8 cm CDs without an adapter.



1. Press the FUNCTION button to select "CD" function.
2. Press the CD compartment lid (▲ CD OPEN/CLOSE portion). The CD compartment opens.
3. Place the disc with the label facing up on the disc turntable. (Place only one disc at a time.)
4. Press the CD compartment lid (▲ CD OPEN/ CLOSE portion) to close it.
The total number of tracks and total playing time on the disc appear.

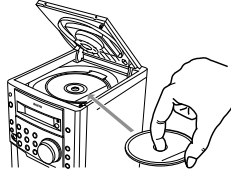

Note:

If the disc is loaded with the label facing downward, or if a badly scratched disc is loaded, "Cd" appears. If this occurs, load the disc correctly or replace the damaged disc.

5. Press the CD button. Play starts from the first track.
The current track number and elapsed playing time are displayed.

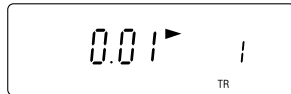

6. Press the □ button to end disc play.
When the last track has been played, the player stops automatically.

Note:

Always press the □ button and wait for the disc to stop rotating before opening the CD compartment.
This unit can play back the CD-R/RW as well. However, some CD-R/RWs can not be played back depending on the recording conditions.

Notes on handling compact discs

- Do not expose the disc to direct sunlight, high humidity or high temperatures for extended periods of time.
- Discs should be returned to their cases after use.
- Do not apply paper or write anything on the disc surface.
- Handle the disc by its edge. Do not touch the playing surface (glossy side).
- Fingerprints and dust should be carefully wiped off the playing surface of the disc with a soft cloth.
Wipe in a straight motion from the centre to the outside of the disc.
- Never use chemicals such as record cleaning sprays, antistatic sprays or fluids, benzene or thinner to clean compact discs.

To start play from the desired track

Select the track by using the ◀◀ or ▶▶ button, then press the CD button.

Using the remote control

Press two number buttons within 2 seconds. (Example: press 0, then 3.)

Temporarily stopping play

Press the CD button (or ▶/|| button on the remote control). "▶" blinks on the display. To resume play, press the button again.

Skip play

To skip to track 6 while track 3 is playing, press the ▶▶ button repeatedly until "6" appears (in the track section) on the display. To skip back to track 3 while track 6 is playing, press the ◀◀ button repeatedly until "3" appears.

- The number buttons on the remote control can also be used for skip play. To skip to track 6 while one track is playing, press 0, then 6.

Search (forward/reverse)

If the ▶▶ or ◀◀ button is pressed during play, the player will search at high speed in the forward or reverse direction while the button is being pressed. When the button is released, normal play will continue.

Repeat play

Press the REPEAT button before or during play. The player will play all the tracks or all the programmed tracks repeatedly. "↺" appears. To cancel repeat play, press the REPEAT button again. "↺" disappears.

PROGRAMMED PLAY

Up to 24 tracks on a disc can be programmed for play in any order.

- First, select "CD" function and load a disc that you want to programme.
- The tracks must be programmed in the stop mode.
- The same track can be programmed more than once.

1. Press the MEMORY button on the remote control.



2. Select a track by using the ▶▶ or ◀◀ button.
 - The number buttons on the remote control can also be used.

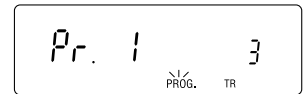

3. Press the MEMORY button on the remote control.

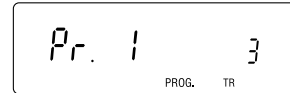

4. Repeat steps 2-3 to programme additional tracks.

5. Press the CD button to start programmed play.
When all programmed tracks have played, the player stops automatically.



- The programme contents are retained in memory.

- Any attempt to programme more than 24 tracks will result in "FULL" being displayed and discontinuation of the programming.
- To cancel programmed play, press the □ button twice.

Checking the programme (Remote control only)

Each time the MEMORY button is pressed in the stop mode, the programmed details sequentially appear on the display.

Changing a programme

To add a new track to a programme: (Remote control only)

1. In the stop mode, press the MEMORY button repeatedly until "- - - -" is displayed.
2. Select a track by using ▶▶ or ◀◀ button.
3. Press the MEMORY button.

To change a track: (Remote control only)

1. In the stop mode, press the MEMORY button repeatedly until the track number to be replaced is displayed.
2. Select a track by using ▶▶ or ◀◀ button.
3. Press the MEMORY button.

Note:

Programmed details cannot be partially deleted or inserted.

LISTENING TO THE RADIO

Before use

When the unit is shipped from the factory, its AM frequency band is set as "522-1710 kHz (in 9 kHz steps)".

If your local AM broadcast system is organized in 10 kHz steps, change the frequency band to "520-1710 kHz (in 10 kHz steps)" as follows:

1. Press the TUNER/BAND button to select AM.
2. While pressing the \square button on the front panel, press the $\triangleright\triangleright$ button on the front panel.

To return the original setting, repeat steps above.

Automatic/Manual tuning

1. Press the FUNCTION button to select TUNER. The radio frequency appears.
2. Press the TUNER/BAND button to select AM or FM.

Automatic tuning

Press the TUNING - or TUNING + button for at least 1 second to tune in a station. The unit will scan up or down the band and receive the next receivable station. Press the button again to continue.

- The \lll or \ggg button on the remote control can also be used.

Manual tuning

Press the TUNING - or TUNING + button briefly until the desired frequency is displayed.

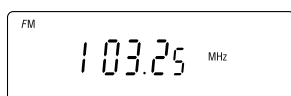

To preset stations (Using remote control)

Up to 24 stations for FM band, 12 stations for AM band, can be preset.

Manual presetting

1. Tune in the station to be preset as described above.
2. Press the MEMORY button.

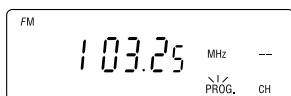

3. Press the PRESET button (or PRESET - or PRESET + button on the front panel) to select the channel number to be preset.

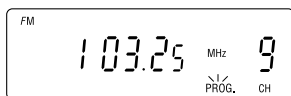

4. While "PROG." is blinking, press the MEMORY button. "PROG." disappears.
 - In this example, "103.25 MHz" FM station is preset on FM channel 9.
 - The number buttons on the remote control can also be used. In this example, press 0, then 9 after the step 2 above.

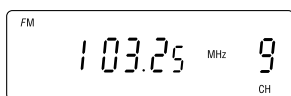

Note:

If the next step is not taken within 10 seconds while performing steps 2 - 4, "PROG." disappears and the preset operation is cancelled. Press the MEMORY button on the remote control to continue.

5. Repeat steps above to add more preset stations.

- When presetting a new station, the previous preset station is cleared.

Automatic presetting (APT)

1. Press the TUNER/BAND button to select FM, AM.
2. Press the MEMORY button for at least 3 seconds. "PROG." blinks. The automatic tuning mode is set and automatic presetting begins from the low end of the band. When 24 stations for FM, 12 stations for AM have been preset or the high end of the band is reached, automatic presetting stop. "PROG." disappears and the previous received station is heard.
3. To preset stations on the other band, follow steps above.

Note:

If APT is activated, all previously programmed stations of the band will be cleared and new stations will be programmed.

Listening to preset stations

1. Press the TUNER/BAND button to select FM, or AM.
2. Press the PRESET - or PRESET + button on the front panel (or PRESET button on the remote control) to select the desired channel number. The selected channel number appears briefly.
 - The number buttons on the remote control can also be used. Press two number buttons within 2 seconds.

Preset scan tuning

1. Select "TUNER" function and select the band.
2. Press the PRESET button for at least 1 second. Each of the preset stations is tuned in for 5 seconds.
3. When the desired station has been tuned in, press the PRESET button again to keep the reception locked at that station.

To receive FM stereo broadcasts

"ST" appears when an FM stereo broadcast is received in the stereo mode.

Make sure the reception mode is in stereo. or else, press the FM MODE button.

- If the signal from an FM stereo station is weak and reception is poor, press the FM MODE button to change to the mono mode. The reception may be improved, but the sound will be monaural.

When beat interference is heard (Remote control only)

A high-pitched noise called "beat" is sometimes heard during reception of radio broadcasts. If this occurs.

1. Press the MEMORY button.
2. When "PROG." is blinking, press the FM MODE button to select "bc-A" or "bc-b". Select the setting that gives the best results.

LISTENING TO TAPES

1. Press the FUNCTION button to select "TAPE".
2. Press the cassette holder (EJECT portion) to open it.
3. Load the cassette.
After loading the cassette, push the cassette holder (EJECT portion) back into position.
4. Press the TAPE button to begin playback.
5. Press the \square button to stop playback at any time. Press it again to remove the cassette.

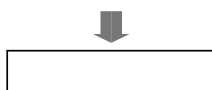
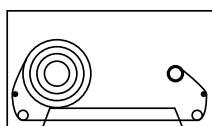

When the end of the tape has been reached, automatic stop will be activated.

Note:

- Use the normal tape (TYPE 1).
- Endless tapes cannot be used.
- Do not use C-100 (or longer) tapes. They may jam in the mechanism.

Fast forward and rewind

Press the \lll or \ggg button. When the desired location has been reached, press the \square button.

LISTENING TO OTHER SOURCES

1. Press the FUNCTION button to select "LINE".

2. Follow the instructions supplied with the Video/Auxiliary equipment.

RECORDING

Recording copyright material without permission of the copyright owners is usually an infringement. If you wish to re-record copyright material, permission from the copyright owner is necessary. SANYO does not approve of, and cannot be held responsible for, any unlawful use of this machine.

Recording compact discs (Synchronous recording)

1. Press the FUNCTION button to select "CD" function.
2. Load the disc to be recorded.
 - For programmed recording, programme the material in advance (as described under "PROGRAMMED PLAY").
3. Select the track number to be recorded if required.
 - For programmed recording, this step is unnecessary.
4. Press the ●/|| button. The deck enters the recording pause mode and "REC" appears. "▶" blinks.
5. Press the TAPE button. Recording starts.
6. Press the □ button to stop recording. Also the CD player stops automatically.

Recording from the tuner or other sources

1. Tune in the radio station to be recorded or play other sources.
2. Press the ●/|| button.
3. Press the TAPE button. Recording starts.
4. Press the □ button to stop recording.

When beat interference is heard (Remote control only)

A high-pitched noise called "beat" is sometimes heard during the recording of radio broadcasts. If this occurs.

1. Press the MEMORY button on the remote control.
2. While "PROG." is blinking, press the ◀◀ button to select "bc-1" or "bc-2". Select the setting that gives the best results.

Automatic record muting (Remote control only)

Undesirable parts of a programme can be omitted while recording. Press the ○ button once while recording. "REC" blinks and a 5-second unrecorded blank space is created, then the deck enters the recording pause mode. "REC" remains lit and "▶" blinks on the display.

- To add another 5-second blank space, press the ○ button again.
- To resume recording, press the TAPE button.

Safeguards against accidental erasure

Accidental erasure can be prevented by breaking out the tabs on the end of the cassette tape (where the tape is not exposed) using a screwdriver or similar implement.

If a tab is broken out in error and you wish to re-record the tape, simply block the tab hole using adhesive tape and the tape can be used for recording again.

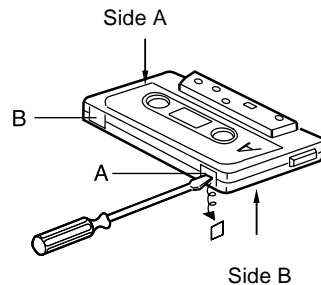

Break out tab A for side A.
Break out tab B for side B.

MAINTENANCE

Cleaning the tape heads

To ensure continued high performance, use cotton swab to clean the heads, pinch roller and capstan of the deck after about every 10 hours of use. If the dirt persists, soak the swab in a little methylated spirit or head cleaning fluid and then clean.

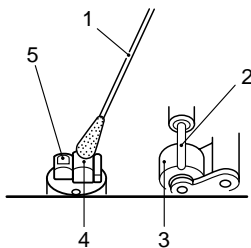

1. Cotton swab
2. Capstan
3. Pinch roller
- 4, 5. Head

Cleaning the CD player lens

The lens should never be touched. If dust is on the lens, blow it off using a camera lens blower. (Consult your dealer.)

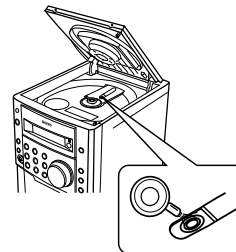

Cleaning the unit

Clean the outside of the unit with a clean soft cloth, moistened with lukewarm water. Do not use benzene, thinner or alcohol since they will mar the finish of the surfaces.

SPECIFICATIONS

Tuner

Reception frequency:

FM: 87.5 - 108 MHz

AM: 522 - 1710 kHz (9 kHz step)

520 - 1710 kHz (10 kHz step)

CD player

Channels:

2-channel stereo

Sampling frequency:

44.1 kHz

Pick-up:

Optical 3-beam semiconductor laser

Laser output:

0.6 mW (Continuous wave max.)

Wave length:

790 nm

Wow/flutter:

Below measurable limits

Cassette deck

Track system:

4-track, 2-channel stereo

Frequency response:

80 Hz to 15 kHz

Signal-to-noise ratio:

40 dB

Wow/flutter:

0.15% (WRMS)

Fast forward/rewind time:

Approx. 110 sec. (C-60)

General

Output power:

4W x 2 (at 4 ohms, 10% distortion)

Outputs:

SPEAKERS: 4 ohms

PHONES: 8 - 32 ohms

Power requirements:

AC 230 ~ 240 V, 50 Hz

Power consumption:

21 W

Dimensions:

150(W) x 230(H) x 205(D) mm

Weight:

2.3 kg

Speaker systems

Type:

Full range bass reflex

Unit used:

10 cm cone type

Maximum power-handling capacity:

8 W (peak)

Nominal impedance:

4 ohms

Dimensions:

145(W) x 230(H) x 170(D) mm

Weight:

1.2kg (per speaker)

Specifications subject to change without notice.