



INSTRUCTION MANUAL

DTL-4800P

Real Time Video Cassette Recorder

English

Real Time-Videorecorder

Deutsch

Magnétoscope en temps réel

Français

Videograbador en tiempo real

Español

Videoregistratore in tempo reale

Italiano

实时录像机

中国简体

DIGITAL



Please read this manual carefully before connecting your VCR and operating it for the first time.
Be sure to read carefully and follow all the PRECAUTIONS on page 1 and 2.
Keep the manual in a safe place for future reference.

PRECAUTIONS

WARNING: TO REDUCE THE RISK OF FIRE OR ELECTRIC SHOCK, DO NOT EXPOSE THIS APPLIANCE TO RAIN OR OTHER MOISTURE. To avoid electrical shock, do not open the cabinet. Refer servicing to qualified personnel only. If the power supply cord (AC power cord) of this appliance is damaged, it must be replaced. Return to a SANYO Authorised Service Centre for replacement of the cord.

CAUTION: Do not put your hand or other objects in the cassette loading slot because of risk of injury or accident. Be sure to keep small children away from the VCR.

IMPORTANT (U. K. Only)
Mains Supply
WARNING – THIS APPARATUS
MUST BE EARTHED

The wires in the mains lead are coloured in accordance with the following code;

| | |
|-------------------|---------|
| GREEN-and-YELLOW: | EARTH |
| BLUE: | NEUTRAL |
| BROWN: | LIVE |

As the colours of the wires in the mains lead of this apparatus may not correspond with the coloured markings identifying the terminals in your plug, proceed as follows.

The wire which is coloured

GREEN-AND-YELLOW must be connected to the terminal in the plug which is marked with the letter E or by the safety earth symbol \perp or coloured GREEN or GREEN-AND-YELLOW.

The wire which is coloured BLUE must be connected to the terminal which is marked with the letter N or which is coloured BLACK. The wire which is coloured BROWN must be connected to the terminal which is marked with the letter L or coloured RED.

Bij dit produkt zijn batterijen geleverd. Wanneer deze leeg zijn, moet u ze niet weggooien maar inleveren als KCA.

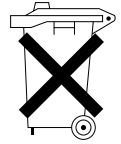

CAUTION

Danger of explosion if battery is incorrectly replaced. Replace only with the same or equivalent type recommended by the manufacturer. Discard used batteries according to the manufacturer's instructions.

ADVARSEL!

Lithiumbatteri-Eksplosionsfare ved fejlagtig håndtering. Udskiftning må kun ske med batteri af samme fabrikat og type. Levér det brugte batteri tilbage til leverandøren.

ADVARSEL

Eksplosjonsfare ved feilaktig skifte av batteri. Benytt samme batteritype eller en tilsvarende type andefalt av apparatfabrikanten. Brukte batterier kasseres i henhold til fabrikantens instruksjoner.

VARNING

Explosionsfara vid felaktigt batteribyte. Använd samma batterityp eller en ekvivalent typ som rekommenderas av apparattillverkaren. Kassera använt batteri enligt fabrikantens instruktion.

VAROITUS

Paristo voi räjähtää jos se on virheellisesti asennettu. Vaihda paristo ainoastaan laitevalmistajan suosittelemaan tyyppiin. Hävitä käytetty paristo valmistajan ohjeiden mukaisesti.

PRECAUTIONS

Location

For safe operation and satisfactory performance of your VCR, keep the following in mind when selecting a place for its installation:

- Shield it from direct sunlight and keep it away from sources of intense heat.
- Avoid dusty or humid places.
- Avoid places with insufficient ventilation for proper heat dissipation. Do not block the ventilation holes of the VCR. Do not place the unit on a carpet because this will block the ventilation holes.
- Install the VCR in a horizontal position only.
- Avoid locations subject to strong vibrations.
- Avoid moving the VCR between cold and hot locations (see “Moisture Condensation Problems”, this page).
- Do not place the VCR directly on top of the TV, as this may cause playback or recording problems.

Avoiding Electrical Shock and Fire

- Do not handle the power cord with wet hands.
- Do not pull on the power cord when disconnecting it from an AC wall outlet. Grasp it by the plug.
- If any liquid is spilled on the VCR, unplug the power cord immediately and have the unit inspected at a factory-authorized service centre.
- Do not place anything directly on top of this VCR.

Moisture Condensation Problems

Cause:

When the VCR is first installed, moved from a cold area to a warm area or placed in a location with high humidity, dew (moisture) may form in the unit. The Dew indicator (d d d d) blinks. If you operate the VCR with dew inside, damage may result.

Prevention:

- ❶ Make all necessary connections.
- ❷ Plug the power cord into a 220 – 240 V AC wall outlet.
- ❸ Do not operate the VCR for approximately 2 hours.

When the VCR reaches room temperature, the Dew indicator (d d d d) will turn off and the VCR will be ready to operation.

About this VCR operation (block recording)

This VCR is equipped with a memory function that, while recording (or playback), will first store the pictures in the internal memory before it actually records them to tape (or outputs them to the screen). This function will prevent damage to the tape and video heads. Therefore, during recording/playback, the tape counter and the tape mechanism will start and stop repeatedly. This is normal and does not indicate a mechanical problem.

During recording:

The images from the camera or other signal input source are first stored to memory, then when the memory reaches its capacity, the images are recorded onto the tape.

During playback:

The images recorded on the tape are first read into the memory, then when the memory reaches its capacity, the images are output to the monitor screen.

Video Cassette Tapes

Use only video cassette tapes bearing the S-VHS logo.

This VCR was primarily designed for use with ST-180XZES cassette tapes, for optimal performance only use ST-180XZES S-VHS videocassettes.

ST-180XZES cassette tapes are available at any dealer where this unit is sold.

Power on/stand-by mode

The power on/stand-by mode is selected by pressing the **STANDBY/ON** button.

VCR display

Stand-by mode

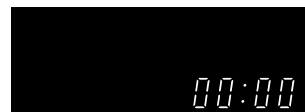

Power on mode



“Stand-by mode” is the condition in which only the time is displayed.

Do not forget that even in the stand-by mode there is an electrical voltage inside the VCR as long as it is connected to a wall socket.

Disconnect the power cord from the wall socket if the VCR is not to be used for a long time.

NOTE:

- When the pre alarm recording setting is other than “OFF”, the **STANDBY/ON** indicator will be on even when the VCR is in stand-by mode.

CONTENTS

| | |
|--|----|
| PRECAUTIONS | 1 |
| FEATURES | 3 |
| ACCESSORIES | 3 |
| LOCATIONS OF CONTROLS AND INDICATORS | 4 |
| CONNECTIONS | 9 |
| ON-SCREEN MENUS | 11 |
| SETTING THE LANGUAGE AND CLOCK | 13 |
| CHANGING THE ON-SCREEN DISPLAY | 15 |
| VIDEO CASSETTE TAPES | 16 |
| TAPE MANAGEMENT FUNCTION | 18 |
| NORMAL RECORDING | 21 |
| AUTOREPEAT RECORDING | 26 |
| ALARM RECORDING | 27 |
| PROGRAMME TIMER RECORDING | 31 |
| RECORDING USING AN EXTERNAL TIMER INPUT | 35 |
| TRIGGER SHOT RECORDING | 36 |
| SERIES RECORDING | 37 |
| PLAYBACK | 39 |
| TAPE COUNTER | 40 |
| DAY/TIME SEARCH | 41 |
| SETTING THE SECURITY LOCK | 42 |
| SETTING THE BUZZER | 43 |
| CLOCK ADJUSTMENT | 44 |
| SETTING THE CASSETTE EJECT MODE | 45 |
| SETUP FOR RS-232C OR RS-485 USE | 46 |
| CHECKING POWER FAILURE, FAILURE DUE TO CONDENSATION AND USAGE DURATION | 48 |
| OUTPUT TERMINALS | 49 |
| MAINTENANCE | 51 |
| TROUBLESHOOTING GUIDE | 53 |
| SPECIFICATIONS | 54 |

FEATURES

- Digital recording/playback
- 520 lines horizontal resolution
- Pre-Alarm and Post-Alarm recording function
- In 12, 24, 48, 72-hour modes audio recording is available
- Can be controlled through an RS-232C or RS-485 connection
- Switchable Time-Date on-screen display
- Tape management function
- Multiple menu language (English/French/German)
- Automatic Summer Time adjustment
- Alarm recording function
- Timer recording function
- Autorepeat recording function
- Series recording function
- Trigger shot recording function
- Alarm search and Alarm scan function
- Day/Time search function
- Clog detection
- Thread check
- Forward/reverse field advance
- Forward/reverse digital view
- Forward/reverse search
- Security lock

ACCESSORIES

Power cord

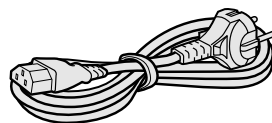

Ni-Cd Battery (battery pack)

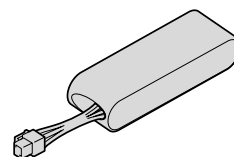

LOCATIONS OF CONTROLS AND INDICATORS

Front Panel

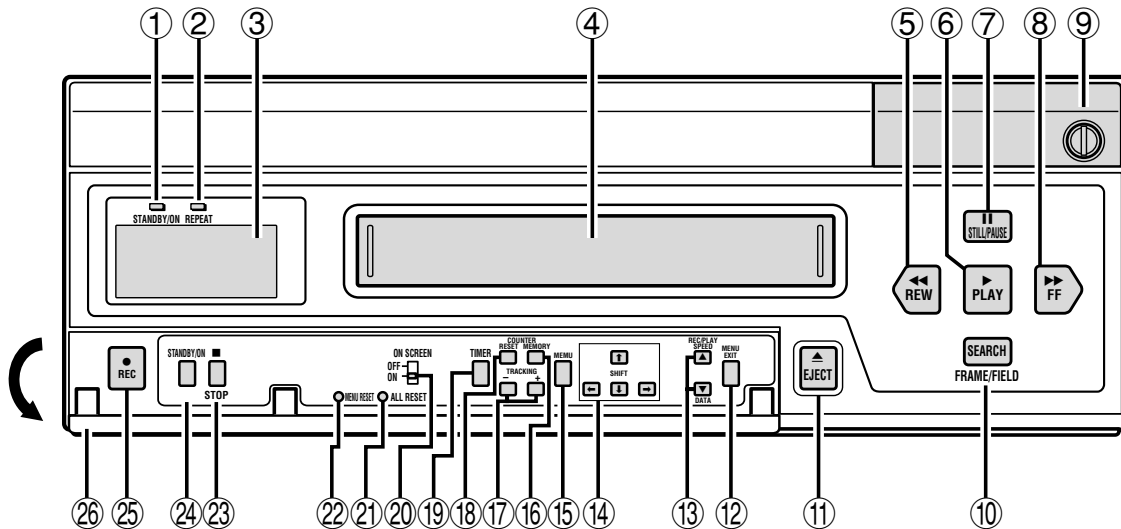

- ① **STANDBY/ON** indicator
- ② **REPEAT** (autorepeat recording) indicator
- ③ Digital display panel
- ④ Cassette loading slot
- ⑤ **REW** (rewind) button
- ⑥ **PLAY** button
- ⑦ **STILL/PAUSE** button
- ⑧ **FF** (fast forward) button
- ⑨ **Ni-Cd** battery compartment
- ⑩ **SEARCH (FRAME/FIELD)** button
- ⑪ **EJECT** button
- ⑫ **MENU EXIT** button
- ⑬ **REC/PLAY SPEED, DATA** ▼, ▲ (decrease, increase recording/playback speed mode, to select numbers or switch settings in reverse order, in order) button.
- ⑭ **SHIFT** ↓, ↑, ←, → (selection, display position down, up, left, right) button
- ⑮ **MENU** button
- ⑯ **COUNTER MEMORY** button
- ⑰ **TRACKING** -, + button
- ⑱ **COUNTER RESET** button
- ⑲ **TIMER** button
- ⑳ **ON SCREEN** switch
- ㉑ **ALL RESET** button
- ㉒ **MENU RESET** button
- ㉓ **STOP** button
- ㉔ **STANDBY/ON** button
- ㉕ **REC** (record) button
- ㉖ Front door

LOCATIONS OF CONTROLS AND INDICATORS

Digital Display

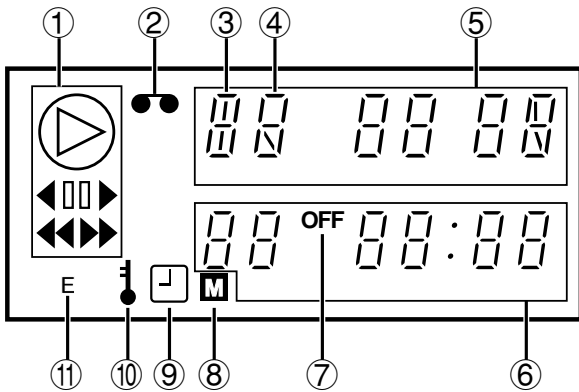

① Operation Indicators

- They display the actual operation mode.

| Operation Mode | Indicator |
|--------------------------|-----------|
| Record (REC) | ○ |
| Record pause (REC PAUSE) | ○ + |
| Playback (PLAY) | ▷ |
| Still image (STILL) | ▷ + |
| Fast forward (FF) | ▶▶ |
| Rewind (REW) | ◀◀ |
| Forward digital view | ▷ + |
| Reverse digital view | ▷ + |
| Forward search | ▷ + ▶▶ |
| Reverse search | ▷ + ◀◀ |
| Forward field advance | ▷ + |
| Reverse field advance | ▷ + |

- Clog detection indicator

Flashes when the recording quality deteriorates due to dirty VCR heads.

- ② Cassette indicator

Comes on when a cassette is loaded.
Flashes during thread check function.

- ③ Alarm indicator

Flashes when an alarm is being recorded:

Comes on after the alarm has been recorded:

- ④ Power failure indicator

Comes on after a power failure.

- ⑤ Mode display
 - Recording/playback speed mode
 - Alarm search mode
 - Alarm scan mode
 - Dew display

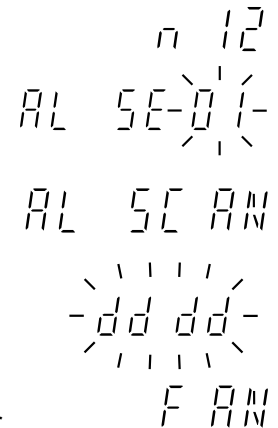

- Cooling fan failure indicator

If the cooling fan does not operate properly, the indicator will flash and the buzzer will be heard. (Press the **STOP** button to stop the buzzer.)
The display will stay on until the cooling fan is repaired. If the unit is used without first repairing the cooling fan, that may cause damages to other components.

- Battery failure indicator

If the battery fails, the indicator will flash and the buzzer will be heard. (Press the **STOP** button to stop the buzzer.)
The display will stay on until the battery is replaced. If the battery is not replaced and there is a power failure, the contents of the memory will be lost (not recorded to the tape).

- ⑤, ⑥ Mode display

- Day/Time search mode

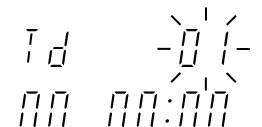

LOCATIONS OF CONTROLS AND INDICATORS

⑥ Counter display

- Time display

00:00

- Counter display

0 00 00

Automatic tracking display

- - - -

- Flashes while automatic tracking is performed.

Mode display

- Sweep out mode

E n d i n g

Flashes while the memory contents are being recorded onto the tape after the end of the recording or the **STOP** button has been pressed to stop recording.

- Back up mode

00 [UP

Flashes (up to 20 seconds) when the power is restored to the unit, if the power has been interrupted during recording.

NOTES:

- Will not be displayed, if the power failure lasts more than 20 seconds.
- May not be displayed according to the memory contents and power failure duration.

⑦ OFF indicator **OFF**

Comes on when the tape end has been reached after a recording.

⑧ Counter memory indicator **M**

Comes on when the counter memory function is engaged.

⑨ Timer Recording indicator

Comes on when in timer recording stand-by mode, or during a timer recording.

⑩ Security lock indicator

Comes on when the security lock is engaged.

⑪ External timer input indicator **E**

Comes on when recording using the **EXT TIMER IN** input terminal.

LOCATIONS OF CONTROLS AND INDICATORS

Back Panel

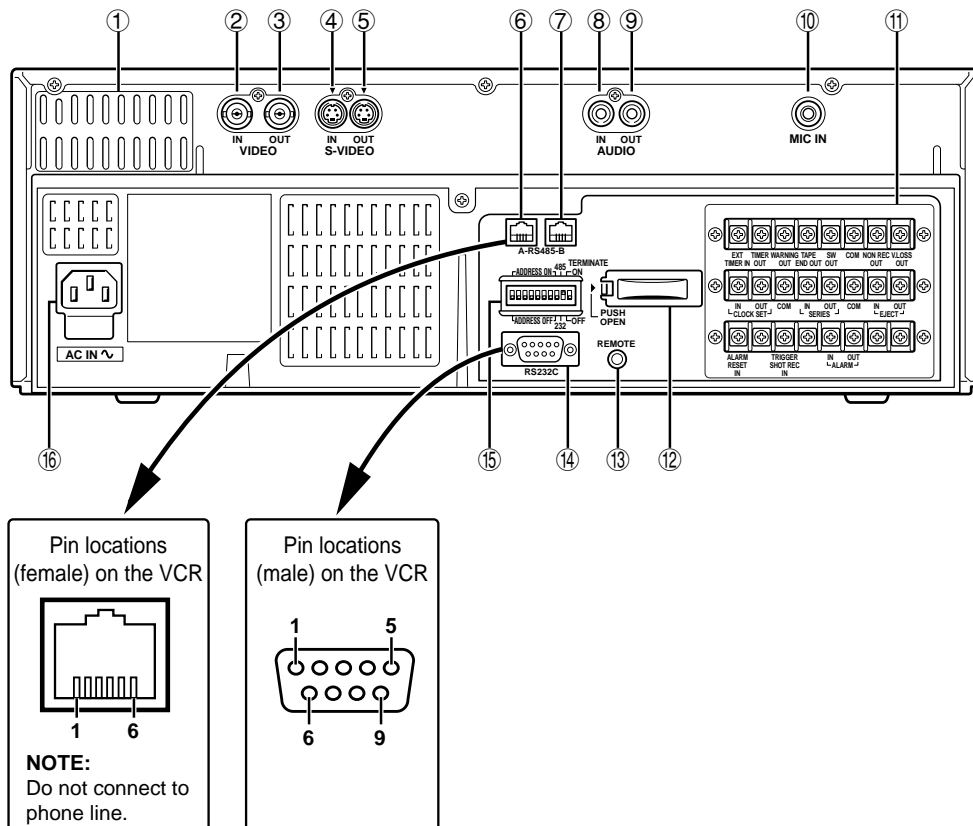

- ① Ventilation opening
NOTE: The cooling fan is located behind this opening, make sure it is not blocked.
- ② VIDEO IN (video input) jack
- ③ VIDEO OUT (video output) jack
- ④ S-VIDEO IN (S-VHS video input) jack
- ⑤ S-VIDEO OUT (S-VHS video output) jack
- ⑥ RS485 A connector (RJ11 type)
- ⑦ RS485 B connector (RJ11 type)
- ⑧ AUDIO IN (audio input) jack
- ⑨ AUDIO OUT (audio output) jack
- ⑩ MIC IN (microphone input) jack
- ⑪ Various terminals (see page 8)
- ⑫ Lithium Battery compartment
- ⑬ REMOTE (remote control input) jack
- ⑭ RS232C connector (D-sub 9-pin type)
- ⑮ DIP switches
 - Used when controlling the VCR through the RS485 or the RS232C connectors.
- ⑯ AC power input

LOCATIONS OF CONTROLS AND INDICATORS

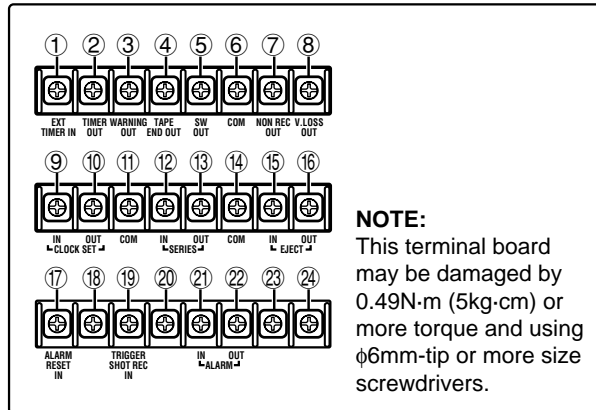

- ① EXT TIMER IN (external timer input) terminal
- ② TIMER OUT (timer recording output) terminal
- ③ WARNING OUT (warning output) terminal
- ④ TAPE END OUT (tape end output) terminal
- ⑤ SW OUT (switch output) terminal
- ⑥ COM (common) terminal
- ⑦ NON REC OUT (non recording output) terminal
- ⑧ V. LOSS OUT (video loss output) terminal
- ⑨ CLOCK SET IN (external clock set trigger input) terminal
- ⑩ CLOCK SET OUT (external clock set trigger output) terminal
- ⑪ COM (common) terminal
- ⑫ SERIES IN (series recording trigger input) terminal
- ⑬ SERIES OUT (series recording trigger output) terminal
- ⑭ COM (common) terminal
- ⑮ EJECT IN (eject trigger input) terminal
- ⑯ EJECT OUT (eject trigger output) terminal
- ⑰ ALARM RESET IN (alarm reset input) terminal
- ⑱ Do not use
- ⑲ TRIGGER SHOT REC IN (trigger shot recording trigger input) terminal
- ⑳ Do not use
- ㉑ ALARM IN (alarm input) terminal
- ㉒ ALARM OUT (alarm output) terminal
- ㉓ Do not use
- ㉔ Do not use

CONNECTIONS

INSTALLING THE Ni-Cd BATTERY

The supplied Ni-Cd battery should be installed correctly before using the VCR.

- 1 Unscrew the Ni-Cd battery compartment screw until the cover can be opened (the screw cannot be removed from the cover).

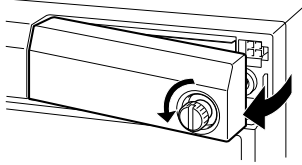

- 2 Insert the battery in the support with the wires facing out.

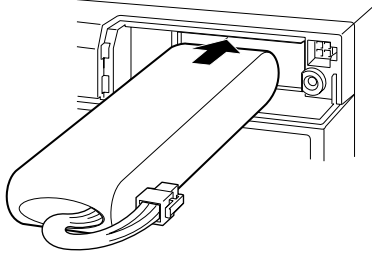

- 3 Checking for correct plug alignment, connect it to the connector on the VCR, then push the wires in, out of the way.

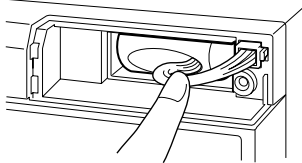

- 4 Install the Ni-Cd battery compartment cover, then tighten the screw (make sure the cover does not pinch the wires).

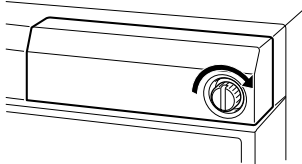

Protection against power failure

In case of a power failure during recording, the Ni-Cd battery will power the VCR until all the memory contents are recorded onto the tape.

When the Ni-Cd battery reaches the end of its useful life, "b" will flash on the digital display and the buzzer will be heard.

The battery useful life may vary according to operating conditions, but it should normally last around 2 years.

WARNING:

- Do not short-circuit the battery pack terminals, and never try to disassemble or modify the battery pack.
- Do not throw it into a fire, as it may explode.
- Do not expose the battery to moisture.
- Do not drop or subject it to violent shock.
- Do not expose to dropping or splashing water.

CAUTION

To prevent the battery from leaking, overheating or exploding follow the precautions below.

- Do not open or modify.
- Do not remove or cut the external tube.
- Do not submit to strong shock.
- Do not use in any other VCR model other than this one (DTL-4800P).

If the liquid gets into your eyes, you may lose your eyesight. Do not rub your eyes, rinse your eyes immediately with clean water, then seek medical attention.

If the batteries leak and liquid gets on your hands or clothing it may cause injury or damages, rinse immediately with clean water.

Do not hold by the connector or connecting wire.

CONNECTIONS

Connect the video camera and monitor TV as shown in the figure below.

NOTE: Before making the connections, make sure the devices are disconnected from the power outlet.

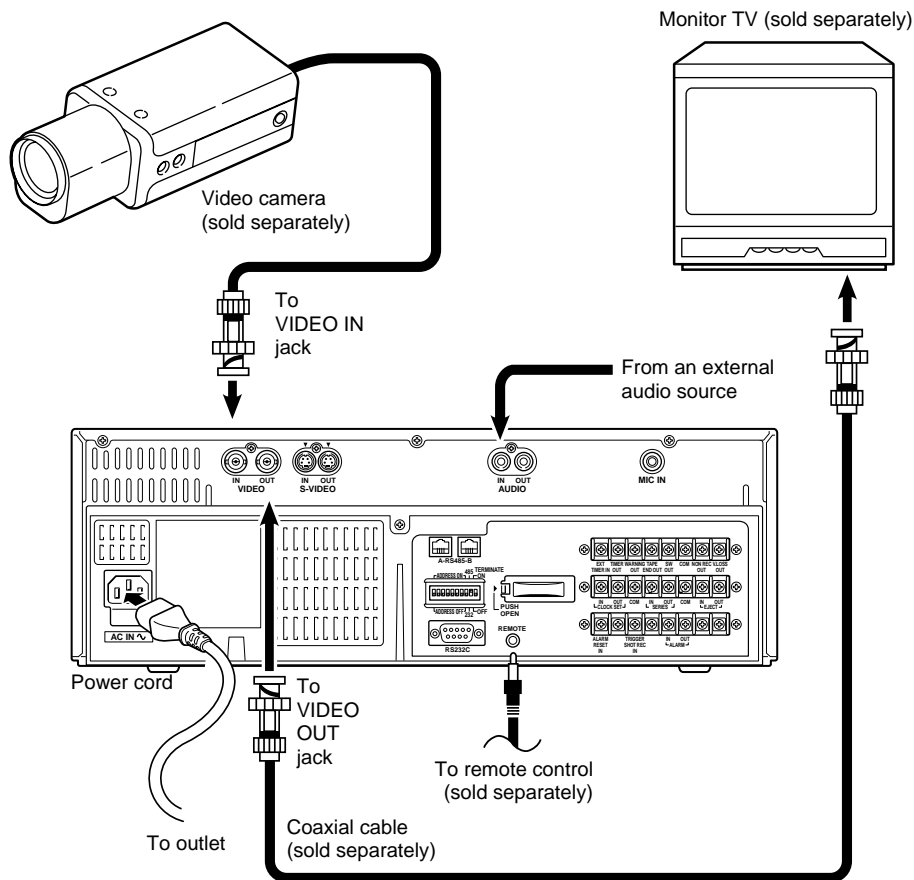

Power Cord Installation

- ❶ Plug the supplied power cord firmly into the AC power input **AC IN** ~ socket.
- ❷ Insert the plug of this power cord into a outlet.

NOTES:

- For more details, please refer to the manuals accompanying all other devices. If the connections are not made properly, it may cause a fire or damage the equipment.
- You can use a VA-RMN01 Remote Control Unit (sold separately) to control remotely the VCR.
- The grounded power cord (3 pin plug) must be connected to a grounded power outlet.
- If there is no video signal when the power is turned on, "NO VIDEO" will be displayed on-screen.
- When both the VIDEO IN jack and S-VIDEO IN jack are connected, the S-VIDEO IN jack will have priority.
- When a multiplexer is used, a connection must be made between the **SW OUT** terminal on the VCR and the **SW IN** terminal on the multiplexer. If the connection is not made, depending on the recording mode a part of the image may not be recorded.

ON-SCREEN MENUS

Main menus

- ① When no menu is displayed on-screen, press the **MENU** button.
 - *The (MAIN MENU 1) menu appears.*
 - When the first line "1. LANGUAGE/CLOCK SET" of the (MAIN MENU 1) is flashing, press the **SHIFT ↑** button or when the last line "9. TAPE MANAGEMENT" is flashing, press the **SHIFT ↓** button to go to the (MAIN MENU 2).
 - When the first line "1. RS-485 SET" of the (MAIN MENU 2) is flashing, press the **SHIFT ↑** button or when the last line "4. SECURITY LOCK" is flashing, press the **SHIFT ↓** button to go to the (MAIN MENU 1).
- When a main menu is displayed, press the **SHIFT ↓** or **SHIFT ↑** button to select a sub-menu. When the desired sub-menu is flashing, press the **MENU** button to select it.
- Press the **MENU EXIT** or **SEARCH** button to return to the monitor screen.

Sub-menus

- ① From within one of the main menus, press the **SHIFT ↓** or **SHIFT ↑** button to select one of the sub-menus, then press the **MENU** button.
 - *The selected sub-menu appears.*
 - To enter or modify settings within a sub-menu, press the **SHIFT ↓**, **SHIFT ↑**, **←** or **→** button to move the selection to the desired setting, then press the **DATA ▼** (or **▲**) button to enter or modify the setting.
- Press the **MENU** button to save any setting made and switch menu screens.
- Press the **MENU EXIT** or **SEARCH** button to save the settings and return to the monitor screen.

Reference pages are shown in square brackets.

MAIN MENU 1 menu

```

<MAIN MENU 1>
1. LANGUAGE/CLOCK SET
2. DISPLAY SET
3. BUZZER SET
4. VARIOUS SET 1
5. VARIOUS SET 2
6. RECORD SET
7. TIMER SET
8. HOLIDAY SET
9. TAPE MANAGEMENT
   TO MAIN MENU 2
  
```

MAIN MENU 2 menu

```

<MAIN MENU 2>
1. RS-485 SET
2. ALARM LOG
3. POWER/DEW/USED TIME
4. SECURITY LOCK
   TO MAIN MENU 1
  
```

LANGUAGE/CLOCK SET menu

```

<LANGUAGE/CLOCK SET>
*LANGUAGE-LANGUE-SPRACHE [13]
  ENGLISH

*CLOCK SET [13]
  01-01-2000 SAT 00:00:00

*SUMMER TIME SET NO USE [14]
  WEEK MONTH TIME
  ON LST-SUN 03 02:00
  OFF LST-SUN 10 02:00
  
```

DISPLAY SET menu

```

<DISPLAY SET> [15]
DATE Y
TIME Y
ALARM COUNT Y
SPEED Y
ALARM NOTATION Y
  
```

NOTE:

- Line 1. of the (MAIN MENU 2) menu will change according to the DIP switch 9 setting. When down "1. RS-232C SET" is displayed and when up "1. RS-485 SET" is displayed.

BUZZER SET menu

```

<BUZZER SET> [43]
*BUZZER SET UP
ALARM IN Y
TAPE END Y
KEY IN N
WARNING Y
THREAD CHECK Y
VIDEO LOSS Y
NON REC Y
CLOG DETECT. Y
  
```

ON-SCREEN MENUS

VARIOUS SET 1 menu

```

<VARIOUS SET 1>
*THREAD CHECK Y [17]
*REMOTE EJECT [50]
*EXT TIME ADJ. 01:00 [44]
*TAPE END OUT PRE [49]
*EJECT SET [45]
  EJECT MODE EJECT1
  OPERATION SLAVE
  
```

RS-485 SET (or RS-232C SET) menu

```

<RS-485 SET> [46-48]
DATA SPEED 19200
STATUS INFO Y
ALARM INFO Y
ADDRESS 000
  
```

VARIOUS SET 2 menu

```

<VARIOUS SET 2>
*TAPE IN MODE STOP [17]
*VIDEO LOSS Y [24]
*REC SPEED N [25]
*CLOG DETECT. Y [23]
*SERIES REC IN N [37,38]
*MX SANYO [25]
  
```

ALARM LOG menu

```

<ALARM LOG> 000 [28]
001 -----:--
002 -----:--
003 -----:--
004 -----:--
005 -----:--
006 -----:--
007 -----:--
008 -----:--
009 -----:--
010 -----:--
  
```

RECORD SET menu

```

<RECORD SET>
*ALARM RECORD MODE Y1 [27,28]
  SPEED N12
  DURATION 20S
*PRE ALARM RECORD OFF [30]
*POST ALARM RECORD OFF [30]
  DURATION 20S
*TRIGGER SHOT REC 1 [36]
*TAPE END MODE REW [24]
  
```

POWER/DEW/USED TIME menu

```

<POWER FAILURE> [48]
000 FAILURE -----:--
  RECOVERY -----:--
<DEW> [48]
000 FAILURE -----:--
  RECOVERY -----:--
<USED TIME> [48]
VIDEO 00000H
POWER 00000H
  
```

TIMER SET menu

```

<TIMER SET> [31-35]
WEEK START STOP SPD
SUN ---:-- ---:-- --- N
MON ---:-- ---:-- --- N
TUE ---:-- ---:-- --- N
WED ---:-- ---:-- --- N
THU ---:-- ---:-- --- N
FRI ---:-- ---:-- --- N
SAT ---:-- ---:-- --- N
DLY ---:-- ---:-- --- N
EXT ***** ***** --- N
  
```

SECURITY LOCK menu

```

<SECURITY LOCK> [42]
*PASS WORD ----
*TIMER NO USE
ON ---:--
OFF ---:--
  
```

HOLIDAY SET menu

```

<HOLIDAY SET> [33]
1 ----- 11 -----
2 ----- 12 -----
3 ----- 13 -----
4 ----- 14 -----
5 ----- 15 -----
6 ----- 16 -----
7 ----- 17 -----
8 ----- 18 -----
9 ----- 19 -----
10 ----- 20 -----
  
```

TAPE MANAGEMENT menu

```

<TAPE MANAGEMENT> [18-20]
*TAPE MANAGE. N
*PROTECT DAY 30

*REC PASS SET 10
*GROUP NO. OFF
*OVERRIDE N
  
```

NOTES:

- When a menu is displayed, recording will not be possible.
- During recording or playback the menus cannot be displayed.
- To reset the settings of a menu to their original values, select the desired menu then press the **MENU RESET** button. The (USED TIME) menu data cannot be reset.
- If a remote control circuit is used to control the unit and the SECURITY LOCK menu is displayed, pressing the remote control **MENU** button will return to the monitor screen display. Pressing the **MENU** button on the unit will display the LANGUAGE/CLOCK SET menu.

SETTING THE LANGUAGE AND CLOCK

Language Setting

English, French or German can be selected by the user.

- 1 Turn the power on to all devices used.
- 2 Press the **MENU** button to display the (MAIN MENU 1) menu.

```
<MAIN MENU 1>
1. LANGUAGE/CLOCK SET
2. DISPLAY SET
3. BUZZER SET
4. VARIOUS SET 1
5. VARIOUS SET 2
6. RECORD SET
7. TIMER SET
8. HOLIDAY SET
9. TAPE MANAGEMENT
TO MAIN MENU 2
```

- 3 Press the **MENU** button to display the (LANGUAGE/CLOCK SET) menu.

```
<LANGUAGE/CLOCK SET>
*LANGUAGE-LANGUE-SPRACHE
ENGLISH

*CLOCK SET
01-01-2000 SAT 00:00:00

*SUMMER TIME SET NO USE
WEEK MONTH TIME
ON LST-SUN 03 02:00
OFF LST-SUN 10 02:00
```

- 4 Press the **DATA** ▼ (or ▲) button to select the language of your choice.
 - To set the clock after having set the language, press the **SHIFT** ↓ button, then continue with step 4, under "Clock Setting".
The menu language will now be the one selected.
- 5 Press the **MENU EXIT** button to save the setting.

Clock Setting

Example: To set the clock to October 15, 2001 at 3:20 PM (15:20).

- 1 Press the **MENU** button to display the (MAIN MENU 1) menu.

```
<MAIN MENU 1>
1. LANGUAGE/CLOCK SET
2. DISPLAY SET
3. BUZZER SET
4. VARIOUS SET 1
5. VARIOUS SET 2
6. RECORD SET
7. TIMER SET
8. HOLIDAY SET
9. TAPE MANAGEMENT
TO MAIN MENU 2
```

- 2 Press the **MENU** button to display the (LANGUAGE/CLOCK SET) menu.

```
<LANGUAGE/CLOCK SET>
*LANGUAGE-LANGUE-SPRACHE
ENGLISH

*CLOCK SET
01-01-2000 SAT 00:00:00

*SUMMER TIME SET NO USE
WEEK MONTH TIME
ON LST-SUN 03 02:00
OFF LST-SUN 10 02:00
```

- 3 Press the **SHIFT** ↓ button, until the "CLOCK SET" setting is flashing.
- 4 Press the **DATA** ▼ (or ▲) button to set the day (ex: 15), then press the **SHIFT** → button.
 - The day of week is set automatically.
- 5 Press the **DATA** ▼ (or ▲) button to set the month (ex: 10), then press the **SHIFT** → button.
- 6 Press the **DATA** ▼ (or ▲) button to set the year (ex: 2001), then press the **SHIFT** → button.
- 7 Press the **DATA** ▼ (or ▲) button to set the hours (ex: 15 for 3 PM), then press the **SHIFT** → button.
- 8 Press the **DATA** ▼ (or ▲) button to set the minutes (ex: 20), then press the **SHIFT** → button.

```
<LANGUAGE/CLOCK SET>
*LANGUAGE-LANGUE-SPRACHE
ENGLISH

*CLOCK SET
15-10-2001 MON 15:20:00

*SUMMER TIME SET NO USE
WEEK MONTH TIME
ON LST-SUN 03 02:00
OFF LST-SUN 10 02:00
```

- 9 For accurate clock setting, press the **DATA** ▼ button together with a time broadcast, or other accurate time signal, this will start the seconds counting from 00.
- 10 Press the **MENU EXIT** button to save the setting.

SETTING THE LANGUAGE AND CLOCK

NOTES:

- Clock display is only 24 hours.
- In STOP mode, press and hold the **STOP** button then press the **TRACKING –** button to reset the minutes and seconds to “00” (to the closest hour). For example, between 13:30:00 and 14:29:59 the clock is reset to 14:00:00.
- If a cassette tape is not loaded, you can reset the seconds to “00” by pressing the **COUNTER RESET** button.

Automatic Summer Time Adjustment

- ➊ Follow steps ➊ and ➋ under “Clock Setting”.
- ➋ Press the **SHIFT ↓** button, until the “SUMMER TIME SET” setting is flashing.
- ➌ Press the **DATA ▼** (or **▲**) button to set the auto summer time/standard time adjustment.
 - NO USE No summer time/standard time adjustment is made.
 - USE The auto summer time/ standard time adjustment is made.
- ➍ Press the **SHIFT ↓** button until “LST” of the “ON” line is flashing.
- ➎ Set the day the summer time adjustment is made.
 - Press the **DATA ▼** (or **▲**) button to set the week, then press the **SHIFT →** button.
 - 1ST, 2ND, 3RD, 4TH or LST (first, second, third, fourth or last)
 - Press the **DATA ▼** (or **▲**) button to set the day of week, then press the **SHIFT →** button.
 - SUN, MON, TUE, SAT (Sunday, Monday, Tuesday....Saturday)
- ➏ Press the **DATA ▼** (or **▲**) button to set the month the summer time adjustment is made, then press the **SHIFT →** button.
 - 01, 02,.....11, 12 (for January, February.....November, December)
- ➐ Press the **DATA ▼** (or **▲**) button to set the time the summer time adjustment is made.
- ➑ Press the **SHIFT ↓** and **→** button until “LST” of the “OFF” line is flashing.
- ➒ Following the same procedure as above (steps ➎ to ➐), set when the time is changed back from summer time to standard time.
- ➓ Press the **MENU EXIT** button to save the setting.

CHANGING THE ON-SCREEN DISPLAY

Selecting the On-screen Display

You can select to display or not the date, time, the number of alarm recordings, tape speed and alarm indication.

- 1 Turn the power on to all devices used.
- 2 Press the **MENU** button to display the (MAIN MENU 1) menu.

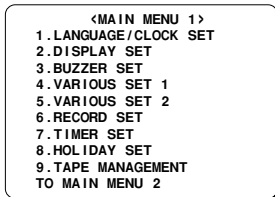

- 3 Press the **SHIFT** ↓ button to select the “2. DISPLAY SET” line, then press the **MENU** button.
 - The (DISPLAY SET) menu appears.

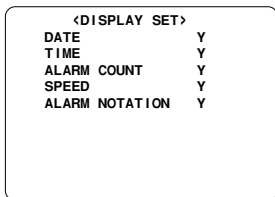

- 4 Press the **SHIFT** ↓ button, until the desired item for which the display function will be set is flashing.
- 5 Press the **DATA** ▼ (or ▲) button to set “Y” for the desired functions described below.

| | |
|-------------------|---|
| DATE | The date is displayed |
| TIME | The time is displayed |
| ALARM COUNT . . . | The number of alarm recordings is displayed |
| SPEED | The recording/playback speed mode is displayed |
| ALARM NOTATION | The alarm recording type (pre alarm recording, alarm recording or post alarm recording) will be displayed. The message “PRE ALARM, ALARM or POST ALARM” will flash under the clock display. |

NOTE:

- “PRE ALARM” will only be displayed during playback.

- 6 Press the **MENU EXIT** button to save the settings.

Changing the Date/Time Display Position

- 1 Turn the power on to all input devices to the VCR.
- 2 Set the **ON SCREEN** switch to the “ON” position.
 - The date and time are displayed.

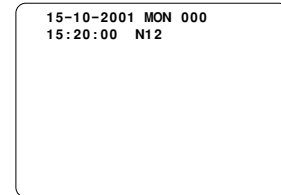

- 3 Press the **SHIFT** ↑, ↓, → or ← button.
 - The display will move up, down, right or left.

NOTE:

- If the **SHIFT** ↑, ↓, → or ← button is kept pressed for 1 second or more the display will move at a faster speed.

VIDEO CASSETTE TAPES

Use only video cassette tapes bearing the S-VHS logo.

This VCR was primarily designed for use with ST-180XZES cassette tapes, for optimal performance only use ST-180XZES S-VHS videocassettes.

ST-180XZES cassette tapes are available at any dealer where this unit is sold.

Handling Cassette Tapes

The cassette tapes should always be stored vertically, in their cases, away from high temperatures, magnetic fields, direct sunlight, dirt, dust and locations subject to mold formation.

Do not tamper with the cassette mechanism and never touch the tape with your fingers.

Protect the cassette tapes from shocks or strong vibrations.

To Protect your Recordings

After having recorded a tape, if you wish to keep the recording, use a flathead screwdriver to break off the erasure-prevention tab on the cassette.

To record again on a tape without erasure-prevention tab, cover the hole with adhesive tape.

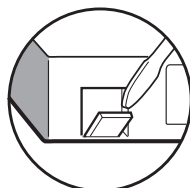
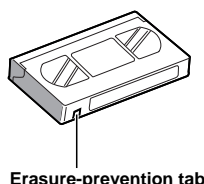

Precautions concerning the video cassette tapes

- Do not use tapes that are damaged, tapes that have been cut and repaired or tapes that have been altered in any way.
- Some rewinders may entangle the tape, and therefore their use is not recommended.
- When tapes are recorded over and over again, the recording quality will deteriorate. Refer to "Concerning the Number of Times Tapes can be Rerecorded on" on page 23, and replace the tape with a new tape as required.

Loading

- ① Place the cassette, label side up, in the loading slot. Gently push the centre of the cassette until it is loaded automatically.

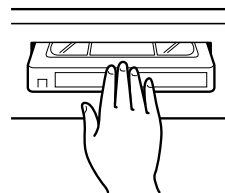

- The time display will switch to the reset counter "0 00 00" display.
- After the cassette tape is loaded, a mechanism will operate for about 12 seconds to check that the tape has been threaded correctly and the cassette indicator "●●" will blink during that period.
- When the cassette is loaded, if the tape has been threaded correctly, the cassette indicator "●●" will light on the digital display.

NOTES:

- If you try to record on a cassette without erasure-prevention tab, the VCR will eject the cassette.
- If a VHS cassette tape is inserted, it will be ejected automatically.

Unloading

- ① In stop mode, press the **EJECT** button.
 - The cassette is automatically ejected.

NOTES:

- Do not insert any object in the cassette loading slot, as that may cause injury and damages to the VCR.
- If your hand gets stuck in the cassette loading slot, unplug the power cord and consult the dealer where the unit was bought. Do not forcibly pull the hand out as that may cause severe injuries.

VIDEO CASSETTE TAPES

Correct tape thread check function

If the correct tape thread check function is on, after the cassette tape is loaded, a mechanism will operate for about 12 seconds to check that the tape has been threaded (loaded) correctly and the cassette indicator “●●” will blink during that period. If the tape is not loaded properly, the cassette will be ejected.

NOTES:

- This function checks to make sure that the cassette has been correctly loaded. It is recommended to use this function to make sure the recordings are conducted reliably.
 - If during the tape thread check operation, the **REC**, **PLAY**, **FF**, **REW** or **STOP** button is pressed, the command will only be executed after the tape thread has been checked. Only the **EJECT** button will operate while the tape thread is being checked.
 - If in the (VARIOUS SET 2) menu “TAPE IN MODE” is set to “REC”, the recording indicator “○” will light while the tape thread is checked. However, recording will only start after the tape thread check is completed. To cancel recording, press the **STOP** button.
- ① Press the **MENU** button to display the (MAIN MENU 1) menu.
 - ② Press the **SHIFT ↓** button to select the “4. VARIOUS SET 1” line, then press the **MENU** button.
 - The (VARIOUS SET 1) menu appears.

| <VARIOUS SET 1> | |
|-----------------|--------|
| *THREAD CHECK | Y |
| *REMOTE | EJECT |
| *EXT TIME ADJ. | 01:00 |
| *TAPE END OUT | PRE |
| *EJECT SET | |
| EJECT MODE | EJECT1 |
| OPERATION | SLAVE |

- ③ Press the **DATA ▼** (or **▲**) button to set the desired mode.
 - Y The correct tape thread check function is on
 - N The correct tape thread check function is off
- ④ Press the **MENU EXIT** button to save the setting.

Setting the Action to Take When a Cassette is Loaded

You can set the mode the VCR will go into when a cassette is loaded.

- ① Press the **MENU** button to display the (MAIN MENU 1) menu.
- ② Press the **SHIFT ↓** button to select the “5. VARIOUS SET 2” line, then press the **MENU** button.
 - The (VARIOUS SET 2) menu appears.

| <VARIOUS SET 2> | |
|-----------------|-------|
| *TAPE IN MODE | STOP |
| *VIDEO LOSS | Y |
| *REC SPEED | N |
| *CLOG DETECT. | Y |
| *SERIES REC IN | N |
| *MX | SANYO |

- ③ Press the **DATA ▼** (or **▲**) button to set the desired mode.
 - STOP Stays in stop mode
 - REC Goes into recording mode
- ④ Press the **MENU EXIT** button to save the setting.

TAPE MANAGEMENT FUNCTION

This VCR is equipped with a tape management function. Using this function you can protect previous recordings and prevent overuse of the tape by controlling the tape protection term (number of days), the maximum number of re-recordings of the tape and the recording group. To use the tape management function, it must be set before recording is started. The tape management data is recorded at the beginning of the tape. For details on how to set this function, refer to "Setting the Tape Management Function".

PROTECT DAY: To set the number of days before the tape can be rerecorded over.

REC PASS SET: To limit the number of rerecordings, in order to maintain a good image quality.

GROUP NO.: To manage tapes belonging to different recording groups.

NOTE:

- Before using this function, make sure that the clock is set properly.

Operation

When recording is started, the VCR will rewind the tape to the beginning, and will playback some of the tape to check for the presence of tape management data (no image is displayed). While the presence and type of data are checked, the message "T. MANAGE. CHK" is displayed on-screen.

NOTES:

- When a programme timer recording is set, the tape management data is checked after the **TIMER** button is pressed to complete the programme timer recording setting.
- When performing trigger shot recording and alarm recording, the tape management function will not operate even if it is active.

If no tape management data is present on the tape

Recording will start according to the settings in the (TAPE MANAGEMENT) menu.

When recording starts, the updated tape management data is recorded onto the tape.

If the tape has already been recorded on, the message "USED TAPE" will flash on-screen until recording starts.

If tape management data is present on the tape

The tape management data is checked and if there is no conflict, the VCR will rewind the tape to the beginning, then recording starts and the updated tape management data is recorded onto the tape. While the tape is rewound and the tape management data recorded, the message "T. MANAGE. OK" is displayed on-screen.

If a conflict is found when the tape management data is checked, the (TAPE MANAGEMENT) menu is displayed and the conflicting setting will flash. This menu will show the settings taken from the data recorded on the tape and not the current data settings held in the VCR's (TAPE MANAGEMENT) menu setting. Refer to "Tape Management Conflict Display" for detailed information.

NOTES:

- During Autorepeat recording, the tape management data at the beginning of the tape will be checked and updated every time the tape is rewound to the beginning. However, the "PROTECT DAY" setting will be ignored. Also, even if there is a conflict with the "REC PASS SET" number, autorepeat recording will continue without any warning.
- If the VCR is set for alarm recordings, alarm recording will be done based on the different settings. If an alarm trigger is received while the tape is being first rewound, the tape will continue to be rewound to the beginning, then alarm recording will be done after the tape has been advanced of a preset duration. If an alarm trigger is received while the message "T. MANAGE. CHK" is displayed on-screen, in order to prevent erasing the tape management data recorded at the beginning of the tape, the tape is advanced of a preset duration, then alarm recording starts. If an alarm trigger is received while tape management data is being recorded onto the tape, alarm recording will only start after all the data has been recorded. Furthermore, when setting a programme timer recording, in order to protect the data, no alarm trigger will be received until the first programme timer recording starts.

IMPORTANT NOTES:

- If the tape management data cannot be read, the VCR will switch to stop mode and "DATA NG" will be displayed on-screen. This may indicate that the beginning of the tape (data recording/reading section) is damaged and the tape may be unusable. The message "DATA NG" will disappear when the **EJECT, STOP** or **PLAY** button is pressed.
- **Set the security lock function to on in order to protect the security of this feature.**

TAPE MANAGEMENT FUNCTION

Setting the Tape Management Function

- ❶ Press the **MENU** button to display the (MAIN MENU 1) menu.
- ❷ Press the **SHIFT ↓** button to select the “9. TAPE MANAGEMENT” line, then press the **MENU** button.
 - *The (TAPE MANAGEMENT) menu appears.*

| <TAPE MANAGEMENT> | |
|-------------------|-----|
| *TAPE MANAGE. | N |
| *PROTECT DAY | 30 |
| | |
| *REC PASS SET | 10 |
| *GROUP NO. | OFF |
| *OVERRIDE | N |

- ❸ Press the **DATA ▼** (or **▲**) button to select the desired mode.
 - N The tape management function is not active.
 - Y The tape management function is active.

When setting to “Y”, please continue with the settings below.

- ❹ Press the **SHIFT ↓** button, until the “PROTECT DAY” setting is flashing.
- ❺ Press the **DATA ▼** (or **▲**) button, to select the desired number of days to protect the tape.
 - OFF The tape is not protected.
 - 1-255 Number of days to protect the tape (prevent over-recording), from the date of the last recording on the tape (or the last expected recording date (calculated using the tape length (ST-180XZES) and the recording speed).

NOTES:

- Since the last expected recording date is a calculated date (using the tape length (ST-180XZES) and the recording speed), it may be different from the actual last recording date, this due to other settings such as (alarm recordings, programme timer recordings, holiday settings).
 - When setting a programme timer recording, the tape protection term is checked when the VCR is set to programme timer recording stand-by mode.
 - When a programme timer recording is done, the data is updated when recording starts. Even if the recording is stopped before the programmed time, the original data (last expected recording date) will remain as calculated.
- ❻ Press the **SHIFT ↓** button, until the “REC PASS SET” setting is flashing.
 - ❼ Press the **DATA ▼** (or **▲**) button, to select the desired number of re-recording times.

- OFF The number of re-recording times will not be checked.
- 1-100 Maximum number of re-recording times.

(Refer to “Concerning the Number of Times Tapes can be Rerecorded on” on page 23.)

NOTES:

- The data is updated at the beginning of the recording. Even if the recording is stopped before the end, the original data information will be considered.
 - During Autorepeat recording, the re-recording times count will be updated every time the tape is rewound to the beginning. Autorepeat recording will proceed even if the count exceeds the “REC PASS SET” setting. If in the (BUZZER SET) menu WARNING is set to “Y”, the buzzer is heard.
- ❽ Press the **SHIFT ↓** button, until the “GROUP NO.” setting is flashing.
 - ❾ Press the **DATA ▼** (or **▲**) button, to select the desired group number.
 - OFF The group number will not be checked.
 - 1-15 Group number setting.
 - ❿ Press the **SHIFT ↓** button, until the “OVERRIDE” setting is flashing.
 - ⓫ Press the **DATA ▼** (or **▲**) button, to select the desired override mode.
 - Y In case of a conflict that prevents recording, the next operation is executed. If recording is done, then the last recording date and the re-recording times count are updated.
 - N In case of a conflict that prevents recording, the (TAPE MANAGEMENT) menu is displayed and the conflicting setting preventing recording will flash. The only possible action is to press the **EJECT** button, in order to eject the tape. (Refer to “Tape Management Conflict Display”).
 - ⓬ Press the **MENU EXIT** button to save the settings.

NOTES:

- **Once the tape management data is recorded on tape, it cannot be changed.**
- The criteria (condition) for allowing recording will be based on the data recorded on the tape and not the settings in the (TAPE MANAGEMENT) menu.

TAPE MANAGEMENT FUNCTION

Tape Management Conflict Display

If when the tape management function checks the tape data a conflict that prevents recording is found, the (TAPE MANAGEMENT) menu is displayed with the conflicting setting flashing and the VCR go into stop mode. If in the (BUZZER SET) menu, WARNING is set to "Y", the buzzer is heard. (To stop the buzzer, press the **STOP** button.)

NOTES:

- If "OVERRIDE" is set to "N" (No), the conflicting setting is displayed flashing and the message (PRESS EJECT) is displayed at the bottom of the screen. Recording under these conditions is not possible. Press the **EJECT** button to eject the tape. To record on the same tape, set the **OVERRIDE** setting to "Y" and modify the conflicting setting, then insert the same tape and press the **REC** button. However, if only "PROTECT DAY" and "REC PASS SET" are modified, the menu will be displayed again. Press the **REC** button one more time to start recording. Recording starts and the tape data is updated.

Conflict display sample

```
<TAPE MANAGEMENT>
*TAPE MANAGE.   N
*PROTECT DAY   30
LAST D/M       NEXT D/M
 15/12         16/1
*REC PASS SET   10
PASS COUNT     10
*GROUP NO.     7
REC GR.NO.     8
*OVERRIDE      N
(PRESS EJECT)
```

- If the "OVERRIDE" is set to "Y" (Yes), the (TAPE MANAGEMENT) menu is displayed and conflicting setting preventing recording will flash and VCR go into the stop mode. To enter the record mode, press the **REC** button.

PROTECT DAY CONFLICT

The tape is protected, the tape protection term (ex. 30 days) is not yet over.

Under **LAST D/M**, the date of the last recording on the tape (or the last expected recording date (calculated using the tape length (ST-180XZES) and the recording speed)) is displayed.

Under **NEXT D/M**, the date when it will be possible to record on the tape again is displayed.

REC PASS SET CONFLICT

The set number of recording passes has been reached.

The **PASS COUNT** shows the number of recording passes on the tape (ex. since the maximum number of recording passes is set to "10", this prevents further recording.)

NOTES:

- When conducting Autorepeat recording, if the **PASS COUNT** exceeds 100, "101*" will be displayed flashing.
- If using a tape recorded previously on a different type of VCR (no tape data), when the set number of recordings is exceeded, "USED" will flash next to the **PASS COUNT** number.

GROUP NO. CONFLICT

The group numbers do not match.

The **REC GR. NO.** shows the tape recording group number (ex. this tape belongs to a different recording group number 8 than the one set 7.)

NORMAL RECORDING

Normal Recording

Before starting

- Turn the power on to all devices used.
- Load a cassette tape with erasure-prevention tab.

NOTES:

- If in the (VARIOUS SET 2) menu, TAPE IN MODE is set to "REC", recording will start after the tape thread has been checked.

- 1 Press the **REC/PLAY SPEED** ▼ (or ▲) button to set the recording speed mode.
 - *The recording speed mode is displayed on the digital display.*
- 2 Press the **REC** button.
 - *The record indicator "○" light.*
 - *Recording starts.*
 - *If the tape end is reached while recording, "OFF" is displayed on the digital display and the unit goes into the mode set at the "TAPE END MODE" line in the (RECORD SET) menu.*

NOTES:

- If the tape end is reached during recording, the memory contents will be erased without being recorded.
 - If in the (BUZZER SET) menu, TAPE END is set to "Y", the buzzer will be heard as long as "OFF" is displayed on the digital display.
 - To cancel the "OFF" display, press the **STOP**, **EJECT**, **FF**, **REW** or **PLAY** button.
- 3 To stop recording, press the **STOP** button.
 - *While the contents of the memory are recorded onto the tape, "Ending" (Sweep out mode display) flashes and "○" (Recording mode display) is displayed on the digital display.*

NOTES:

- A tape recorded on this VCR cannot be played back on other models of VCRs.
- If you press on the **REC** button and the loaded cassette has no erasure-prevention tab, the VCR will eject the cassette.
- This VCR will first store the recorded images in its internal memory before recording them to the tape. Due to this method of recording blocks of images, the tape counter will not operate continuously. (The tape counter will operate for about 9 seconds, then stop (the duration until it starts again depends on the recording speed mode setting) and start again.)

When recording is started, the counter will only start operating after the memory is full.

Record Pause

Recording can be interrupted temporarily.

- 1 Press the **STILL/PAUSE** button during recording.
 - *The Pause/Still indicator "⏏" blinks.*

NOTE:

- The image appears on-screen but it is not recorded.
- 2 To resume recording, press the **REC** button, or press the **STILL/PAUSE** button again.

NORMAL RECORDING

[Recording Speed Mode]

Recording speed mode and single picture data size relation table

The numbers indicate the rate at which the images are stored into the memory (number of fields (or frames) per second)

| Recording speed mode (hour mode) | Minimum recording duration (hour) | Single picture data size | | | | | |
|----------------------------------|-----------------------------------|--------------------------|---------------|---------------|---------------|---------------|----------------|
| | | 16.8kByte/field | 25kByte/field | 33kByte/field | 50kByte/field | 67kByte/field | 100kByte/frame |
| 12 | 12 | – | – | 25 (N) | 16.7 (U) | 12.5 (H) | 8.33 (F) |
| 24 | 24 | 25 (E) | 16.7 (L) | 12.5 (N) | – | 6.25 (H) | 4.17 (F) |
| 48 | 48 | – | 8.33 (L) | 6.25 (N) | – | 3.12 (H) | 2.08 (F) |
| 72 | 72 | – | – | – | – | 2.08 (H) | 1.39 (F) |
| 96 | 96 | – | – | – | – | 1.56 (H) | 1.04 (F) |
| 120 | 120 | – | – | – | – | 1.25 (H) | 0.83 (F) |
| 168 | 168 | – | – | – | – | 0.89 (H) | 0.59 (F) |
| 240 | 240 | – | – | – | – | 0.625 (H) | 0.42 (F) |
| 360 | 360 | – | – | – | – | 0.417 (H) | 0.28 (F) |
| 480 | 480 | – | – | – | – | 0.313 (H) | 0.21 (F) |
| 720 | 720 | – | – | – | – | 0.208 (H) | 0.14 (F) |
| 960 | 960 | – | – | – | – | 0.156 (H) | 0.10 (F) |

The code (E, L, N, U, H, or F) within brackets indicates the picture quality. The picture quality (E) being the lowest and (F) the highest. (E: Extended low picture quality recording, L: Low picture quality recording, N: Normal picture quality recording, U: Upper picture quality recording, H: High picture quality recording, F: Frame recording).

The codes E, L, N, U and H indicate field recording and the code F indicates frame recording.

The picture quality code is displayed at the left of the recording speed mode.

Audio recording/playback is only possible in 12-, 24-, 48- and 72-hour modes.

The accumulated picture to memory mode (rate) is selected according to the recording speed mode and picture quality code.

NOTES:

- At playback, the picture quality code cannot be selected. The playback speed mode is selected and the picture quality code is set automatically according to the recording speed mode and the picture quality code selected for recording.
- The picture quality code “N” is displayed as “n” on the digital display.
- The indicated minimum recording duration in the table is for recording to the end on an ST-180XZES tape. The actual recording duration may be longer according to the kind of recorded pictures.
- When used for recording through a multiplexer, set the multiplexer camera switching interval to a longer setting than the recording interval. (For example, when recording in F12-hour recording mode (8.33 frames/sec), set the interval to a value bigger than 0.13 sec.)

NORMAL RECORDING

Concerning the Number of Times Tapes can be Rerecorded on

Depending on the recording speed mode, the tape must be replaced after a certain number of recording times.

Refer to the table below for the maximum number of times a tape can be recorded on.

| Recording speed mode (hour mode) | Maximum number of recording times |
|----------------------------------|-----------------------------------|
| 12 | 100 |
| 24 | 100 |
| 48 | 100 |
| 72 | 100 |
| 96 | 100 |
| 120 | 100 |
| 168 | 100 |
| 240 | 70 |
| 360 | 45 |
| 480 | 35 |
| 720 | 20 |
| 960 | 10 |

NOTES:

- The maximum number of recording times will vary depending on the location and kind of tape used. Verify the recording quality and replace the tape when the quality starts to deteriorate. The maximum number of recording times indicated above are based on test tapes (ST-180XZES) used by the company.
- If using other types of tape, the tape travel will not be as stable and that may cause problems.

Recording Check

The image being recorded can be checked.

- 1 During recording, press the **PLAY** button.

- *The tape will be rewound and then played back. The VCR will then return to the previous recording mode.*

NOTES:

- Recording will resume about 30 seconds after the **PLAY** button has been pressed.
- When the recording check is done, according to the memory contents, the recording speed mode may be changed temporarily while the recording is made onto the tape.

Clog Detection

This VCR is equipped with a clog detection function.

The recording quality is monitored automatically. When the heads are dirty and the recording quality deteriorates, the output at the **WARNING OUT** terminal becomes 0V (Low), the "○" indicator flashes on the digital display. If in the (BUZZER SET) menu, CLOG DETECT. is set to "Y", the buzzer will heard.

If in the (VARIOUS SET 2) menu, CLOG DETECT. is set to "N", the recording quality is not monitored.

NOTE:

- If the **STOP** button is pressed, recording is stopped, the **WARNING OUT** terminal output, the "○" display and the buzzer sounding will be canceled.

NORMAL RECORDING

Setting the Mode at the End of the Tape

You can set the VCR mode when the tape reaches the end during recording.

- ❶ Press the **MENU** button to display the (MAIN MENU 1) menu.
- ❷ Press the **SHIFT ↓** button to select the "6. RECORD SET" line, then press the **MENU** button.
 - *The (RECORD SET) menu appears.*

| <RECORD SET> | |
|--------------------|-----|
| *ALARM RECORD MODE | Y1 |
| SPEED | N12 |
| DURATION | 20S |
| *PRE ALARM RECORD | OFF |
| *POST ALARM RECORD | OFF |
| DURATION | 20S |
| *TRIGGER SHOT REC | 1 |
| *TAPE END MODE | REW |

- ❸ Press the **SHIFT ↓** (or **↑**) button, until the "TAPE END MODE" setting is flashing.
 - If "TAPE END MODE" is set to "R1" or "R2" (see step ❷), "REPEAT RECORD" will be indicated instead of "TAPE END MODE".
- ❹ Press the **DATA ▼** (or **▲**) button to set the desired mode.

Setting when not using Autorepeat recording

- REW Rewinds the tape to the beginning, then goes to stop mode
- STOP Goes to stop mode
- EJECT The cassette is ejected

Setting when using Autorepeat recording

- R1 Autorepeat recording mode is automatically canceled if there was an alarm trigger
- R2 Autorepeat recording mode is active even if there was an alarm trigger

- ❺ Press the **MENU EXIT** button to save the setting.

Action to Take when the Video Signal Deteriorates

If there is no video signal during recording or when a menu is not displayed (in stop, fast forward or rewind modes), "VIDEO LOSS" can be displayed on-screen and a signal (0 V) can be output at the **V. LOSS OUT** terminal. If in the (BUZZER SET) menu, VIDEO LOSS is set to "Y", the buzzer will be heard. To stop the buzzer, press the **STOP** button.

- ❶ Press the **MENU** button to display the (MAIN MENU 1) menu.
- ❷ Press the **SHIFT ↓** button to select the "5. VARIOUS SET 2" line, then press the **MENU** button.
 - *The (VARIOUS SET 2) menu appears.*

| <VARIOUS SET 2> | |
|-----------------|-------|
| *TAPE IN MODE | STOP |
| *VIDEO LOSS | Y |
| *REC SPEED | N |
| *CLOG DETECT. | Y |
| *SERIES REC IN | N |
| *MX | SANYO |

- ❸ Press the **SHIFT ↓** button, until the "VIDEO LOSS" setting is flashing.
- ❹ Press the **DATA ▼** (or **▲**) button to set the desired mode.
 - N The video loss warning is not active.
 - Y The video loss warning is active.
- ❺ Press the **MENU EXIT** button to save the setting.

NORMAL RECORDING

Changes to the Recording Speed Mode During Recording

It is possible to permit or prevent changing the recording speed mode during recording.

- 1 Press the **MENU** button to display the (MAIN MENU 1) menu.
- 2 Press the **SHIFT ↓** button to select the “5. VARIOUS SET 2” line, then press the **MENU** button.
 - The (VARIOUS SET 2) menu appears.

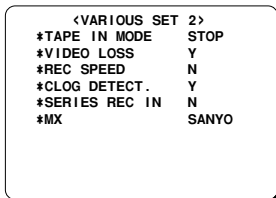

- 3 Press the **SHIFT ↓** button, until the “REC SPEED” setting is flashing.
- 4 Press the **DATA ▼** (or **▲**) button to set the desired mode.
 - N Recording speed mode can not be changed
 - Y Recording speed mode can be changed
- 5 Press the **MENU EXIT** button to save the setting.

Setup for use with a multiplexer

This setting will indicate if a multiplexer is used or not during recording.

- 1 Press the **MENU** button to display the (MAIN MENU 1) menu.
- 2 Press the **SHIFT ↓** button to select the “5. VARIOUS SET 2” line, then press the **MENU** button.
 - The (VARIOUS SET 2) menu appears.
- 3 Press the **SHIFT ↓** (or **↑**) button, until the “MX” setting is flashing.
- 4 Press the **DATA ▼** (or **▲**) button to select the desired setting.
 - SANYO A SANYO brand multiplexer is used.
 - ROBOT A ROBOT brand multiplexer is used.
 - OTHERS A multiplexer other than SANYO or ROBOT is used.
 - N No multiplexer used.
- 5 Press the **MENU EXIT** button to save the setting.

NOTE:

- During playback the distinction is made automatically.

AUTOREPEAT RECORDING

Autorepeat Recording

The same tape can be recorded over many times.

- Follow the **Before starting** steps, under “NORMAL RECORDING”.
- ❶ Press the **MENU** button to display the (MAIN MENU 1) menu.
- ❷ Press the **SHIFT ↓** button to select the “6. RECORD SET” line, then press the **MENU** button.
 - *The (RECORD SET) menu appears.*

| | |
|--------------------|-----|
| <RECORD SET> | |
| *ALARM RECORD MODE | Y1 |
| SPEED | N12 |
| DURATION | 20S |
| *PRE ALARM RECORD | OFF |
| *POST ALARM RECORD | OFF |
| DURATION | 20S |
| *TRIGGER SHOT REC | 1 |
| *TAPE END MODE | REW |

- ❸ Press the **SHIFT ↓** (or **↑**) button, until the “TAPE END MODE” (or “REPEAT RECORD”) setting is flashing.
- ❹ Press the **DATA ▼** (or **▲**) button to set to “R 1” or “R 2”. (Please refer to page 24, “Setting the Mode at the End of the Tape”.)
- ❺ Press the **MENU EXIT** button to save the setting.
 - *The REPEAT indicator will light.*
- ❻ Press the **REC/PLAY SPEED ▼** (or **▲**) button to set the recording speed mode.
- ❼ Press the **REC** button.
 - *Recording will start. When the tape end is reached, the VCR will rewind it to the beginning, and recording will resume.*
 - *When the end of the tape is reached, a buzzer will be heard (if in the (BUZZER SET) menu, TAPE END is set to “Y”) and “OFF” will be displayed until the rewinding operation starts.*

NOTES:

- If during autorepeat recording there is an alarm trigger, “A” is displayed on the digital display and alarm recording will take place. (Please refer to page 27, “ALARM RECORDING”.)
- If the “REPEAT RECORD” setting is R 1, the REPEAT indicator will go off if there is an alarm trigger. After alarm recording, the recording will continue to the end of the tape then it will be rewound to the beginning and stop. “OFF” will be displayed on the digital display. To turn off the buzzer (if in the (BUZZER SET) menu, TAPE END is set to “Y”) and the “OFF” display, press the **STOP, EJECT, FF, REW** or **PLAY** button.
- If “A” is displayed on the digital display and the “REPEAT RECORD” setting is R1, autorepeat recording is not possible.

ALARM RECORDING

By connecting the **ALARM IN** terminal to a door switch, an interphone, etc., a recording can be done only when necessary.

Alarm Recording Setting

Alarm recording is performed when there is an input (trigger) at the **ALARM IN** terminal, "A" is displayed on the digital display.

- Make all necessary connections.
 - Follow the **Before starting** steps, under "NORMAL RECORDING".
 - The alarm triggers are received while in recording, stop and stand-by modes.
- ❶ Press the **MENU** button to display the (MAIN MENU 1) menu.
 - ❷ Press the **SHIFT ↓** button to select the "6. RECORD SET" line, then press the **MENU** button.
 - The (RECORD SET) menu appears.

| | |
|--------------------|-----|
| <RECORD SET> | |
| *ALARM RECORD MODE | Y1 |
| SPEED | N12 |
| DURATION | 20S |
| *PRE ALARM RECORD | OFF |
| *POST ALARM RECORD | OFF |
| DURATION | 20S |
| *TRIGGER SHOT REC | 1 |
| *TAPE END MODE | REW |

- ❸ Press the **DATA ▼** (or **▲**) button to set the desired alarm recording mode, then press the **SHIFT ↓** button.
 - Y1 Alarm recording is done when there is an alarm trigger.
 - Y2 Alarm recording is done only when there is an alarm trigger during programmed timer recording.
 - Y3 Alarm recording is done only if there is an alarm trigger and the VCR is not in programmed timer recording mode.
 - Y4 Alarm recording is done only when there is an alarm trigger during programmed timer recording duration. Timer recording is not possible.
 - N Alarm recording is not performed even if there is an alarm trigger.

- ❹ Press the **DATA ▼** (or **▲**) button to select the desired recording speed, then press the **SHIFT ↓** button.
 - N12 N12-hour mode recording
 - U12 U12-hour mode recording
 - H12 H12-hour mode recording
 - F12 F12-hour mode recording
 - H24 H24-hour mode recording
 - F24 F24-hour mode recording
 - NC Recording at the speed already set
- ❺ Press the **DATA ▼** (or **▲**) button to select the desired alarm recording duration (20S, 40S, 1M, 2M, 3M, 4M, 5M or CC).
 - 20S-5M Recording only for the displayed duration
 - CC Recording as long as the alarm signal is being input (minimum 5 seconds)
- ❻ Press the **MENU EXIT** button to save the settings.

NOTES:

- During alarm recording all buttons are disabled.
- If "OFF" is displayed on the digital display, alarm recording is not possible in order to prevent the recorded tape to be recorded over.
- If an alarm trigger is received while alarm recording is in progress, recording duration for the second alarm will be calculated from that point. The alarm counter will register the alarm, but it will not be found during an alarm scan and alarm search.
- If there is a power failure during alarm recording, and the power is restored within the recording set duration, alarm recording will continue.
- If the alarm recording duration is short, the alarms may not be found during an alarm scan or an alarm search. If the alarms are going to be reviewed using alarm scan or alarm search, then in 12-hour mode, 60-second or more recording duration should be used.
- To do alarm recording during series recording, set "ALARM RECORD MODE" to "Y1" or "Y3". Alarm recording will be conducted only if the VCR is recording.

ALARM RECORDING

Alarm Recording Counter Display

- During alarm recording, "A" will be flashing on the digital display.
- If the **ON SCREEN** switch is set to the "ON" position, the alarm recording type "PRE ALARM, ALARM or POST ALARM" and the number of alarms will flash on the monitor screen.
- The maximum display number of alarm recordings is "999", at the next alarm recording the counter will indicate "000".
- When the (ALARM LOG) menu is displayed, press the **MENU RESET** button to reset the alarm counter to "000" (all the data of the (ALARM LOG) menu is reset).

Connections to the ALARM IN/OUT Terminals

- Alarm input signal
Connect a make-contact (no voltage) switch between the **ALARM IN** and **COM** terminals.
- Alarm output signal
Normally DC 5V are output between the **ALARM OUT** and the **COM** terminals. When an alarm input (trigger) is received and the unit is recording, the output falls to 0V. Once the alarm recording is over, the output returns to DC 5V.

ALARM RESET IN terminal

- If the circuit between the **ALARM RESET IN** terminal and **COM** terminals is closed during alarm recording, alarm recording mode is canceled.

Checking the Alarm Recordings Time

The date and time of up to 100 alarm recordings can be displayed.

- 1 Press the **MENU** button to display the (MAIN MENU 1) menu.
- 2 Press the **SHIFT ↓** (or **↑**) button until the (MAIN MENU 2) menu is displayed.

```
<MAIN MENU 2>
1.RS-485 SET
2.ALARM LOG
3.POWER/DEW/USED TIME
4.SECURITY LOCK
TO MAIN MENU 1
```

- 3 Press the **SHIFT ↓** (or **↑**) button to select the "2. ALARM LOG" line, then press the **MENU** button.

- The (ALARM LOG) menu appears.

```
<ALARM LOG> 011
001 25-12 19:00
002 25-11 23:00
003 25-11 15:00
004 25-10 08:00
005 25-10 06:00
006 25-09 20:00
007 25-09 16:35
008 25-09 10:52
009 25-08 11:00
010 25-08 10:30
```

- The number of alarm recordings, and the 10 most recent alarm recording times are displayed.

NOTE:

- Continue pressing the **SHIFT ↓** button to display the next 10 alarm recordings entries. When the number of alarm recording entries reaches 100, the older ones are erased as new ones are memorized.

- 4 Press the **MENU EXIT** button, the normal screen is displayed.

NOTE:

- If the **MENU RESET** button is pressed while the (ALARM LOG) menu is displayed, the displayed data is erased. "A" will be erased from the digital display.

ALARM RECORDING

Alarm Search

To go to the beginning of a desired alarm recording.

- 1 Press the **SEARCH** button during stop mode.
 - "AL SEARCH 01" will be displayed on screen.
- 2 Press the **DATA** ▼ (or ▲) button to set the desired alarm number (1 to 99), then press the **FF** (or **REW**) button.
 - The alarm search will start.
 - Playback will start just before the desired alarm recording, then switch to a still image at the beginning of the desired alarm recording.

NOTE:

- The alarm number is relative to the actual tape position. (Please refer to the illustration below.)

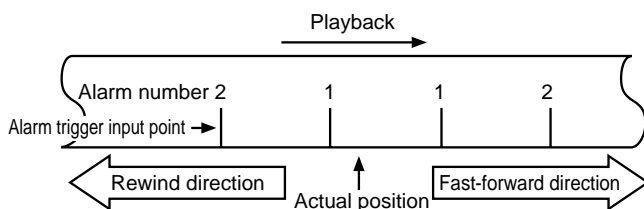

- 3 Press the **PLAY** button.
 - Playback will start.

NOTE:

- If during a search the end of the tape is reached, the tape will rewind and stop. If the beginning of the tape is reached, it will stop.

Alarm Scan

To look for an alarm recording by viewing the first 5 seconds of each alarm recording.

- 1 Press the **SEARCH** button twice during stop mode.
 - "AL SCAN" will be displayed on screen.
- 2 Press the **FF** (or **REW**) button.
 - The unit will advance (or rewind) the tape at high speed and playback the first 5 seconds of every alarm recording.

NOTES:

- The playback of a block which includes the alarm recording will start.
- The playback will continue until the first 5 seconds of the alarm recording are played back.
 - To cancel the alarm scan mode, press the **STOP** button.
- 3 While the desired recording is being played back, press the **PLAY** button.
 - Playback will start, alarm scan mode is cancelled.

NOTE:

- If during a scan the end of the tape is reached, the tape will rewind and stop. If the beginning of the tape is reached, it will stop.

ALARM RECORDING

Pre Alarm Recording Setting

When there is an alarm trigger, the pictures accumulated into the memory previous to the alarm trigger can be recorded using the set recording speed mode (duration).

- This will be activated by an alarm trigger if the "ALARM RECORD MODE" is set to "Y1", "Y3" or "Y4" and the VCR is in stop or stand-by modes.

- 1 Follow steps 1 and 2 under "Alarm Recording Setting" on page 27.

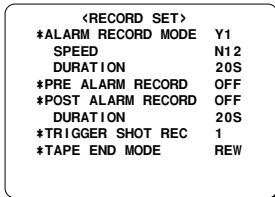

- 2 Press the **SHIFT ↓** button, until the "PRE ALARM RECORD" setting is flashing.

- 3 Press the **DATA ▼** (or **▲**) button to select the recording speed mode.

The recording duration will vary according to the recording speed mode.

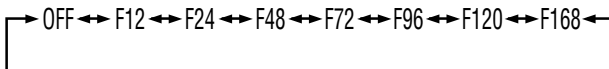

OFF Prealarm recording is not performed

| Recording speed mode | Recording duration (seconds) |
|----------------------|------------------------------|
| F12 | 18 |
| F24 | 36 |
| F48 | 72 |
| F72 | 108 |
| F96 | 144 |
| F120 | 180 |
| F168 | 252 |

- 4 Press the **MENU EXIT** button to save the settings.

Post Alarm Recording Setting

After the alarm recording, you can set recording of the picture to continue at a set recording speed mode, for only a set duration.

- 1 Follow the steps 1 and 2 under "Alarm recording Setting" on page 27.
- 2 Press the **SHIFT ↓** button, until the "POST ALARM RECORD" setting is flashing.
- 3 Press the **DATA ▼** (or **▲**) button to select the recording speed mode, then press the **SHIFT ↓** button.

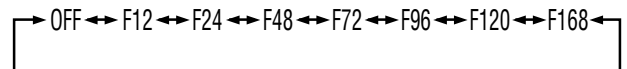

OFF Postalarm recording is not performed

- 4 Press the **DATA ▼** (or **▲**) button to select the postalarm duration. (20S, 40S, 1M, 2M, 3M, 4M, 5M).

20S-5M Recording only for the displayed duration

- 5 Press the **MENU EXIT** button to save the settings.

PROGRAMME TIMER RECORDING

There are two programme timer recording methods, daily recording or recording on certain days of the week.

Example 1: To record on every Saturday from 9:00 AM to 5:00 PM (17:00), in H24-hour mode (recording speed).

- Follow the **Before starting** steps, under “NORMAL RECORDING”.
- ❶ Press the **MENU** button to display the (MAIN MENU 1) menu.
- ❷ Press the **SHIFT ↓** button to select the “7. TIMER SET” line, then press the **MENU** button.
 - The (TIMER SET) menu appears.

| <TIMER SET> | | | |
|-------------|-------|-------|--------|
| WEEK | START | STOP | SPD |
| SUN | --:-- | --:-- | ---- N |
| MON | --:-- | --:-- | ---- N |
| TUE | --:-- | --:-- | ---- N |
| WED | --:-- | --:-- | ---- N |
| THU | --:-- | --:-- | ---- N |
| FRI | --:-- | --:-- | ---- N |
| SAT | --:-- | --:-- | ---- N |
| DLY | --:-- | --:-- | ---- N |
| EXT | ***** | ***** | ---- N |

- ❸ Press the **SHIFT ↓** (or **↑**) button, until “SAT” (Saturday) is flashing.
- ❹ Press the **SHIFT →** button.
 - The recording start hour position starts flashing.
- ❺ Press the **DATA ▼** (or **▲**) button to set the recording start hour (ex: 09), then press the **SHIFT →** button.
 - The recording start minutes position starts flashing.
- ❻ Press the **DATA ▼** (or **▲**) button to set the recording start minutes (ex: 00), then press the **SHIFT →** button.
 - The recording stop hour position starts flashing.
- ❼ Press the **DATA ▼** (or **▲**) button to set the recording stop hour (ex: 17), then press the **SHIFT →** button.
 - The recording stop minutes position starts flashing.

- ❽ Press the **DATA ▼** (or **▲**) button to set the recording stop minutes (ex: 00), then press the **SHIFT →** button.
 - The “SPD” (recording speed) position will start flashing.

NOTE:

- If the set stop time is earlier than or the same time as the set start time, the VCR will consider the stop time to be the following day, and “T” will be displayed next to the recording stop time.
- ❾ Press the **DATA ▼** (or **▲**) button to select the recording speed mode (ex: H24), then press the **SHIFT →** button.
 - “N” will start flashing.
- ❿ Press the **DATA ▼** (or **▲**) button to select the desired programme timer recording mode.
 - Y. Recording will take place
 - N. Recording will not take place

| <TIMER SET> | | | |
|-------------|-------|-------|--------|
| WEEK | START | STOP | SPD |
| SUN | --:-- | --:-- | ---- N |
| MON | --:-- | --:-- | ---- N |
| TUE | --:-- | --:-- | ---- N |
| WED | --:-- | --:-- | ---- N |
| THU | --:-- | --:-- | ---- N |
| FRI | --:-- | --:-- | ---- N |
| SAT | 09:00 | 17:00 | H24 Y |
| DLY | --:-- | --:-- | ---- N |
| EXT | ***** | ***** | ---- N |

- Repeat steps ❸ to ❿ to programme timer recordings for other days of the week.
- ⓫ Press the **MENU EXIT** button to save the settings.
- ⓬ Press the **TIMER** button.
 - The timer recording indicator “” will light on the digital display, the VCR is now in timer recording stand-by mode.

NOTES:

- To modify, cancel or stop timer recording, press the **TIMER** button to cancel the timer recording mode.
- To record everyday at the same time, at step ❸ select the “DLY” line.
- To set two or more timer recordings for a same day of the week, press the **SHIFT ↓, ↑, ← or →** button, until the day of the week for the second recording is flashing, then press the **DATA ▼** (or **▲**) button, to set the desired day of the week.

PROGRAMME TIMER RECORDING

A timer recording of more than 24 hours can only be set on the 7th (SAT) and 8th (DLY) lines of the (TIMER SET) menu.

Example 2: To record every week from Friday at 9:00 PM (21:00) to Monday at 7:00 AM, in H72-hour mode (recording speed).

- Follow the **Before starting** steps, under “NORMAL RECORDING”.
- ❶ Press the **MENU** button to display the (MAIN MANU 1) menu.
- ❷ Press the **SHIFT ↓** button to select the “7. TIMER SET” line, then press the **MENU** button.
 - The (TIMER SET) menu appears.

| <TIMER SET> | | | |
|-------------|-------|-------|-------|
| WEEK | START | STOP | SPD |
| SUN | --:-- | --:-- | --- N |
| MON | --:-- | --:-- | --- N |
| TUE | --:-- | --:-- | --- N |
| WED | --:-- | --:-- | --- N |
| THU | --:-- | --:-- | --- N |
| FRI | --:-- | --:-- | --- N |
| SAT | --:-- | --:-- | --- N |
| DLY | --:-- | --:-- | --- N |
| EXT | ***** | ***** | --- N |

- ❸ Press the **SHIFT ↓** (or **↑**) button, until “SAT” is flashing.
- ❹ Press the **DATA ▼** (or **▲**) button to set the desired start day of the week (ex: FRI), then press the **SHIFT →** button.
 - The recording start hour position starts flashing.
- ❺ Press the **DATA ▼** (or **▲**) button to set the recording start hour (ex: 21), then press the **SHIFT →** button.
 - The recording start minutes position starts flashing.
- ❻ Press the **DATA ▼** (or **▲**) button to set the recording start minutes (ex: 00), then press the **SHIFT →** button.
 - The recording stop hour position starts flashing.
- ❼ Press the **DATA ▼** (or **▲**) button to set “**” for the recording stop hour.
 - The rest of the line settings will change to “**:** * ** *”, the day of the next line will change to the next day and the start time will change to “**:**” automatically.
- ❽ Press the **SHIFT →** and **↓** button, until the day of the week of the 8th line is flashing.

- ❾ Press the **DATA ▼** (or **▲**) button to set the desired stop day of the week (ex: MON), then press the **SHIFT →** button.
 - The recording stop hour position starts flashing.
- ❿ Press the **DATA ▼** (or **▲**) button to set the recording stop hour (ex: 07), then press the **SHIFT →** button.
 - The recording stop minutes position starts flashing.
- ⓫ Press the **DATA ▼** (or **▲**) button to set the recording stop minutes (ex: 00), then press the **SHIFT →** button.
 - The “SPD” (recording speed) position will start flashing.
- ⓬ Press the **DATA ▼** (or **▲**) button to select the recording speed mode (ex: H72), then press the **SHIFT →** button.
 - “N” will start flashing.
- ⓭ Press the **DATA ▼** (or **▲**) button to select “Y”.

| <TIMER SET> | | | |
|-------------|-------|-------|--------|
| WEEK | START | STOP | SPD |
| SUN | --:-- | --:-- | --- N |
| MON | --:-- | --:-- | --- N |
| TUE | --:-- | --:-- | --- N |
| WED | --:-- | --:-- | --- N |
| THU | --:-- | --:-- | --- N |
| FRI | --:-- | --:-- | --- N |
| FRI | 21:00 | **:** | **** * |
| MON | **:** | 07:00 | H72 Y |
| EXT | ***** | ***** | --- N |

- ⓮ Follow steps ❶ and ❷ under “PROGRAMME TIMER RECORDING” on page 31.

PROGRAMME TIMER RECORDING

Setting the Holidays

By setting the holidays, timer recording will be conducted on those days, as set for Sundays.

- 1 Press the **MENU** button to display the (MAIN MENU 1) menu.
- 2 Press the **SHIFT ↓** button to select the “8. HOLIDAY SET” line, then press the **MENU** button.
 - *The (HOLIDAY SET) menu appears.*

| <HOLIDAY SET> | |
|---------------|----|
| 1 | 11 |
| 2 | 12 |
| 3 | 13 |
| 4 | 14 |
| 5 | 15 |
| 6 | 16 |
| 7 | 17 |
| 8 | 18 |
| 9 | 19 |
| 10 | 20 |

- 3 Press the **DATA ▼** (or **▲**) button to set the day of the holiday, then press the **SHIFT →** button.
- 4 Press the **DATA ▼** (or **▲**) button to set the month of the holiday.
- 5 Press the **SHIFT ↓, ↑, ← or →** button until the next line to set is flashing.
 - *Repeat steps 3 to 5 to set up to 20 holidays.*
- 6 Press the **MENU EXIT** button to save the settings.

NOTES:

- If setting holidays, be sure that a timer recording is set for Sunday. If not, this function will not operate.
- If a timer recording for Sundays is entered, the holidays timer recording will not function if the programme timer recording mode is set to “N”.
- To erase a setting, follow the same procedure as above, but at step 3 and 4, enter “--” instead of a setting.

Changing a Programme Timer Recording

- 1 Press the **MENU** button to display the (MAIN MENU 1) menu.
- 2 Press the **SHIFT ↓** button to select the “7. TIMER SET” line, then press the **MENU** button.
 - *The (TIMER SET) menu appears.*
- 3 Press the **SHIFT ↓, ↑, ← or →** button until the setting to correct is flashing.
- 4 Press the **DATA ▼** (or **▲**) button to correct the setting.
- 5 Press the **MENU EXIT** button to save the settings.
- 6 Press the **TIMER** button.

To Cancel a Programme Timer Recording

- 1 Press the **MENU** button to display the (MAIN MENU 1) menu.
- 2 Press the **SHIFT ↓** button to select the “7. TIMER SET” line, then press the **MENU** button.
 - *The (TIMER SET) menu appears.*
- 3 Press the **SHIFT ↓, ↑, ← or →** button until the “Y” corresponding to the timer recording to cancel is flashing.
- 4 Press the **DATA ▼** (or **▲**) button to select “N”.
- 5 Press the **MENU EXIT** button to save the settings.
- 6 Press the **TIMER** button.

To Cancel all Programme Timer Recordings

- 1 Press the **MENU** button to display the (MAIN MENU 1) menu.
- 2 Press the **SHIFT ↓** button to select the “7. TIMER SET” line, then press the **MENU** button.
 - *The (TIMER SET) menu appears.*
- 3 Press the **MENU RESET** button.
 - *All programmed timer recordings are erased.*
- 4 Press the **MENU EXIT** button, the normal screen is displayed.

PROGRAMME TIMER RECORDING

NOTES:

- During timer recording or timer recording stand-by, all the buttons on the VCR, except the **TIMER** button and the buttons to set/cancel the security lock (see page 42), are disabled.
- If the power fails, the recording will be interrupted. When the power is restored, the recording will resume if the stop time has not yet been reached, and "P" will be displayed on the digital display. The VCR internal battery is completely recharged after the VCR has been connected to a live outlet for 48 hours, and it will maintain all the VCR settings memory for up to 30 days.
- Set the timer recordings so that the recording times do not overlap. If they do, the one with the earliest recording start time will have priority. (See chart below.)

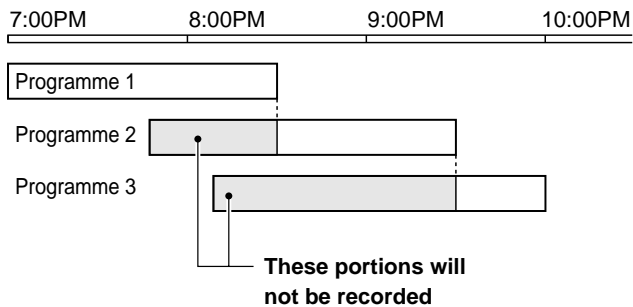

- If no timer recording is set, a cassette is not loaded or a cassette without erasure-prevention tab is loaded, when the **TIMER** button is pressed the timer recording indicator "□" will start flashing and a buzzer will be heard.
- If "OFF" is displayed on the digital display, timer recording is not possible in order to prevent the recorded tape to be recorded over.

RECORDING USING AN EXTERNAL TIMER INPUT

Recording can be controlled by an external start/stop signal input at the **EXT TIMER IN** terminal.

Example 3: To record using the signal input at the **EXT TIMER IN** terminal, in L24-hour mode.

- Follow the **Before starting** steps, under “NORMAL RECORDING”.

NOTE:

- External timer input recording can only be set on the 9th line (EXT) of the (TIMER SET) menu.
- 1 Press the **MENU** button to display the (MAIN MENU 1) menu.
 - 2 Press the **SHIFT ↓** button to select the “7. TIMER SET” line, then press the **MENU** button.
 - *The (TIMER SET) menu appears.*
 - 3 Press the **SHIFT ↓, ↑, ←** or **→** button, until the “SPD” (recording speed) position of the “EXT” line starts flashing.
 - 4 Press the **DATA ▼** (or **▲**) button to select the recording speed mode (ex: L24), then press the **SHIFT →** button.
 - *“N” will start flashing.*
 - 5 Press the **DATA ▼** (or **▲**) button to select “Y”.

| <TIMER SET> | | | |
|-------------|-------|-------|--------|
| WEEK | START | STOP | SPD |
| SUN | --:-- | --:-- | ---- N |
| MON | --:-- | --:-- | ---- N |
| TUE | --:-- | --:-- | ---- N |
| WED | --:-- | --:-- | ---- N |
| THU | --:-- | --:-- | ---- N |
| FRI | --:-- | --:-- | ---- N |
| SAT | --:-- | --:-- | ---- N |
| DLY | --:-- | --:-- | ---- N |
| EXT | ***** | ***** | L24 Y |

- 6 Follow steps 11 and 12 under “PROGRAMME TIMER RECORDING on page 31”.

- *When an external signal is input, “E” will light on the digital display and recording will take place.*

NOTES:

- Other timer recordings using the standard procedure can also be programmed.
- The external input signal must be input at the **EXT TIMER IN** terminal.

TRIGGER SHOT RECORDING

When the trigger shot recording function is set, the set number of frames will be recorded when there is an input at the **TRIGGER SHOT REC IN** terminal.

Trigger Shot Recording Setup

- ❶ In stop mode, press the **REC/PLAY SPEED** ▼ (or ▲) button, to set the recording speed to "000".
- ❷ Press the **MENU** button to display the (MAIN MENU 1) menu.
- ❸ Press the **SHIFT** ↓ button to select the "6. RECORD SET" line, then press the **MENU** button.
 - The (RECORD SET) menu appears.

| <RECORD SET> | |
|--------------------|-----|
| *ALARM RECORD MODE | Y1 |
| SPEED | N12 |
| DURATION | 20S |
| *PRE ALARM RECORD | OFF |
| *POST ALARM RECORD | OFF |
| DURATION | 20S |
| *TRIGGER SHOT REC | 1 |
| *TAPE END MODE | REW |

- ❹ Press the **SHIFT** ↓ (or ↑) button until the "TRIGGER SHOT REC" setting is flashing.
- ❺ Press the **DATA** ▼ (or ▲) button to set the number of frames to record (1, 4, 9 or 16).
- ❻ Press the **MENU EXIT** button to save the settings.
- ❼ Press the **REC** button.
 - The trigger shot recording mode will be activated (the VCR will be in recording stand-by mode).
- ❽ When there is an input (trigger) at the **TRIGGER SHOT REC IN** terminal on the back panel trigger shot recording is done.

NOTES:

- Trigger shot recording can only be conducted in F12-hour recording mode.
- The trigger at the **TRIGGER SHOT REC IN** terminal should be on for 0.1 sec. or more.
- When using the **TRIGGER SHOT REC IN** terminal, connect a make-contact switch (no voltage) between the **TRIGGER SHOT REC IN** and **COM** terminals.

Connections Using a Multiplexer

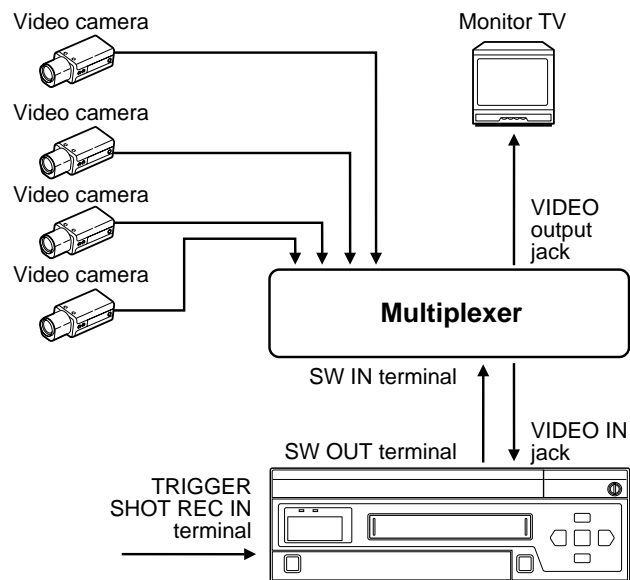

- When a setup using a multiplexer or quad compressor is used, if the number of frames set at step ❺ is the same as the number of cameras, when there is an input at the **TRIGGER SHOT REC IN** terminal one frame from each camera will be recorded.
- For detailed instructions, please refer to the multiplexer or quad compressor instruction manual.

SERIES RECORDING

Using 2 VCRs or more, the series recording function lets you switch recording from one unit to the next (only with VCRs of the same model as this one).

Series Recording Setup

- Connect 2 VCRs or more as illustrated below.
- ❶ Press the **REC/PLAY SPEED** ▼ (or ▲) button to set the recording speed mode.
- ❷ Set the following items as indicated.

| Item | VCR No.1 | VCR No.2 and on |
|---|--------------------|--------------------|
| Cassette tape | Loaded | Loaded |
| Operation mode | Stop | Stop |
| "TAPE END MODE" (in (RECORD SET) menu) | REW, STOP or EJECT | REW, STOP or EJECT |
| Counter memory | Canceled | Canceled |
| "SERIES REC IN" (in (VARIOUS SET 2) menu) | Y (YES) | Y (YES) |
| Timer recording | OFF (not set) | OFF (not set) |
| Power | ON | Stand-by |
| Security lock | Canceled | Set |

- ❸ Press the **REC** button on VCR No.1.
 - *Recording will start in series recording mode.*
- ❹ Set the security lock on VCR No.1.

The SERIES OUT signal will be present either at the point where approximately 5% of the tape remains (if recording has been started at the beginning of the tape) or when VCR No. 1 reaches the end of the tape (if recording has not been started at the beginning of the tape). The signal will stop 70 seconds after the tape end point of VCR No. 1.

When this signal is received by VCR No. 2, it will start recording. During the period when the SERIES OUT signal is being received by VCR No. 2, if the **STOP** button of VCR No. 2 is accidentally pressed, VCR No. 2 will go into the stop mode for an instant and then return to the record mode.

To prevent this from occurring, the security lock of VCR No. 2 should be set to the on condition.

If TAPE END MODE is set to "REW", when the end of the tape is reached "OFF" is displayed, the tape is rewound then stops.

NOTES:

- If approximately 5% of the tape or less remains in VCR No.1, when the **REC** button is pressed (step ❸), the recording will start on VCR No. 2.
- If in the (VARIOUS SET 2) menu "SERIES REC IN" is set to "N", series recording will not be possible.
- The counter must start from the beginning of tape, or the series recording out will not function properly.
- Even if "OFF" is displayed, series recording will be conducted if there is an input at the **SERIES IN** terminal.

Series recording connections

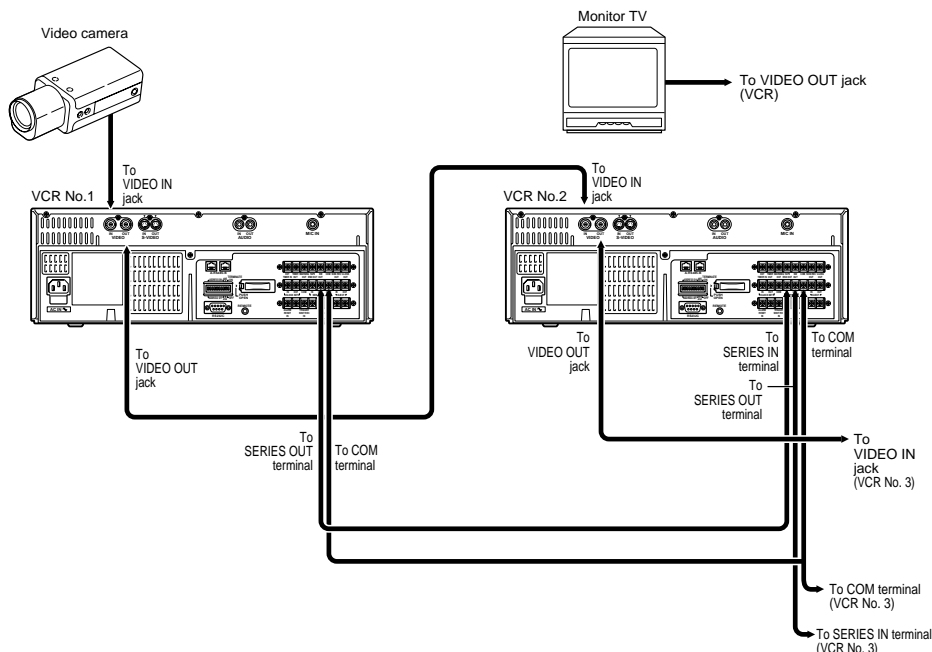

SERIES RECORDING

Continuous Loop Recording Setup

A minimum of 2 units are required for continuous loop recording.

Under loop recording when the recording finishes on the first unit, the new recording will start on the second unit. When the recording finishes on the second unit, recording will start on the first unit.

- The **SERIES OUT** terminal of VCR No.2 and the **SERIES IN** terminal No.1 should be connected (See diagram).

- 1 Press the **REC/PLAY SPEED** ▼ (or ▲) button to set the recording speed mode.
- 2 Set the following items as indicated.

| Item | VCR No.1 | VCR No.2 |
|--|---------------|---------------|
| Cassette tape | Loaded | Loaded |
| Operation mode | Stop | Stop |
| "TAPE END MODE" (in (RECORD SET) menu) | REW | REW |
| Counter memory | Canceled | Canceled |
| "SERIES REC IN" (in VARIOUS SET 2) menu) | Y (YES) | Y (YES) |
| Timer recording | OFF (not set) | OFF (not set) |
| Power | ON | Stand-by |
| Security lock | Canceled | Set |

- 3 Press the **REC** button on VCR No.1.
 - *Recording will start in series recording mode.*
- 4 Set the security lock on VCR No.1.

NOTES:

- To avoid recording problems, the "TAPE END MODE" in (RECORD SET) menu should be set to "REW" for both units.
- In loop recording mode, the tape will be re-recorded over. If you need to keep the recorded information, please eject the tape after recording is complete and insert a new tape.

Loop recording connection (example with 2 VCRs)

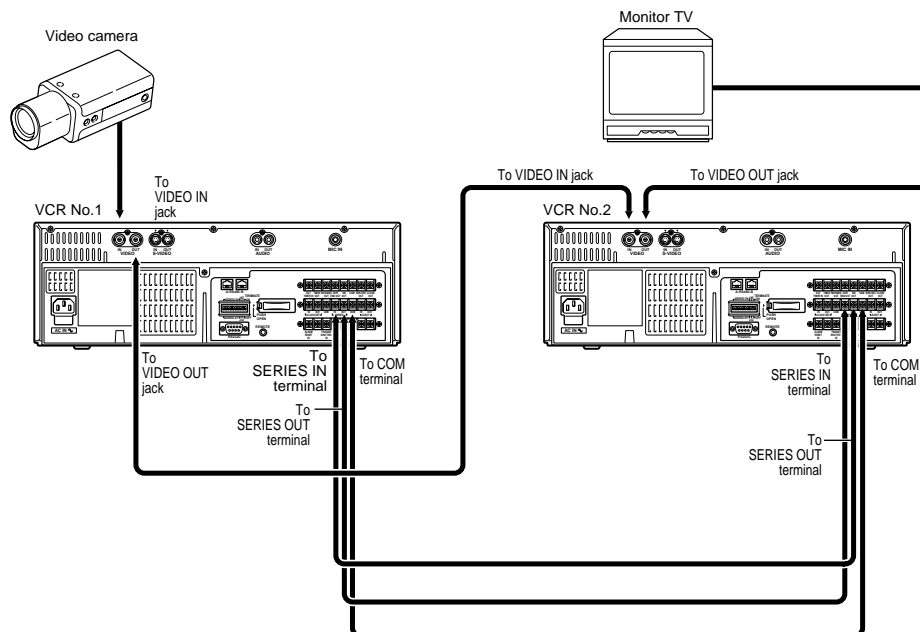

PLAYBACK

Normal Playback

- 1 Turn on the power to the VCR and TV monitor.
- 2 Load the video cassette tape.
- 3 Press the **REC/PLAY SPEED** ▼ (or ▲) button to select the playback speed mode.
 - *The selected playback speed mode is displayed on the digital display.*

NOTES:

- If the playback speed is set to "000", playback (step 4) will not be possible.
 - At playback, the picture quality code cannot be selected and therefore will not be displayed. The playback speed mode is selected and the picture quality code is set automatically according to the recording speed mode and the picture quality code selected for the recording.
 - A slow motion effect or accelerated playback effect can be achieved by using a slower or faster playback speed than the speed used for recording.
- 4 Press the **PLAY** button.
 - *Playback starts.*
 - *The message "NOW LOADING" flashes until the image appears on-screen.*
 - *If necessary, adjust the tracking to clear the picture.*
 - *When the playback of data finishes, the last picture will be displayed frozen on-screen and "NO DATA" will flash on the display.*
 - *When frame recording has been performed, frame playback will be done. "F" will be displayed at the left of the playback speed mode. If the **FRAME/FIELD** button is pressed, field playback will start and the "F" display will disappear. To return to frame playback, press the **FRAME/FIELD** button one more time.*
 - 5 To stop playback, press the **STOP** button.
 - *To advance (or rewind) the tape, press the **FF** (or **REW**) button.*

NOTES:

- A tape recorded on another VCR cannot be played back on this unit.
- If the tape speed is changed during playback, it will be reset to the previous tape speed when playback is stopped.

Tracking Control

If the playback picture is not clear

- 1 Press the **TRACKING +** and – button simultaneously.
 - *"----" flashes while automatic tracking is performed.*

If the playback picture is still not clear

- 1 Press the **TRACKING +** (or –) button until the playback picture is clear.
 - *The playback picture quality can be checked after the tape counter has functioned twice.*
- 2 If the playback picture is still not clear, repeat step 1.

Audio Playback

- Audio playback is only possible in 12-hour, 24-hour, 48-hour and 72-hour modes.
- The playback speed has to be the same as the recording speed, for normal playback of the audio.

Still Image

- 1 Press the **STILL/PAUSE** button, during normal playback.
 - *A still image can be viewed.*
- 2 To return to normal playback, press the **PLAY** button.

NOTES:

- If still mode continues for 5 minutes or more, the VCR will go into stop mode to avoid damaging the tape.
- If a moving subject is recorded on tape using the picture quality code "F", the still image playback may be blurred. In such a case, press the **FRAME/FIELD** button to display a clear image.

Digital View (Forward and Reverse)

- 1 Press the **FF** (or **REW**) button, during normal playback.
 - *The playback will be done in 12-hour mode, independently of the playback speed mode setting.*
- 2 To return to normal playback, press the **PLAY** button.

NOTES:

- The sound is muted.
- If reverse digital view mode continues for 5 minutes or more, the VCR will go into stop mode to avoid damaging the mechanism.
- In reverse digital view mode, a still image playback will be displayed and "NOW LOADING" will flash on-screen while the data is being read to the memory. While the message "NOW LOADING" is displayed, the **PLAY**, **FF**, **REW** and **STILL/PAUSE** buttons will not operate.

PLAYBACK

Search (Forward and Reverse)

- ❶ Press the **FF** button during forward digital view (or press the **REW** button during reverse digital view).
 - A portion of the recorded images will be played back.
 - Large portions of the fields will be skipped and therefore the complete recording cannot be seen.
 - A still image playback will be displayed and "NOW SEARCHING" appears until the next pictures are displayed.
- ❷ To return to normal playback, press the **PLAY** button.
 - You can enter search from fast forward or rewind mode. Press the **FF** button (during fast forward mode) or **REW** button (during rewind mode).

NOTES:

- The sound is muted.
- If reverse search mode continues for 5 minutes or more, the VCR will go into stop mode to avoid damaging the mechanism.

Field Advance (Forward and Reverse)

- ❶ Press the **FF** (or **REW**) button, during still image mode.
 - The still image is advanced (or rewound) of one image (field).
- ❷ To return to normal playback, press the **PLAY** button.

NOTES:

- If the **FF** (or **REW**) button is kept pressed for about 1.5 sec. or more, continuous forward (or reverse) field advance mode will be selected (this mode cannot be selected through the RS-232C or RS-485 connection).
- If reverse field advance mode continues for 5 minutes or more, the VCR will go into stop mode to avoid damaging the mechanism.
- In reverse field advance mode, a still image playback will be displayed and "NOW LOADING" will flash on-screen while the data is being read to the memory. While the message "NOW LOADING" is displayed, the **PLAY**, **FF**, **REW** and **STILL/PAUSE** buttons will not operate.

TAPE COUNTER

Using the counter, it is easy to find a desired recording.

- ❶ Press the **COUNTER RESET** button, at the beginning of the desired recording.
 - The counter will be reset to "0 00 00".
- ❷ Press the **COUNTER MEMORY** button.
 - "M" is displayed on the digital display.
 - To cancel the counter memory function, press the **COUNTER MEMORY** button a second time.
- ❸ After recording or playback, press the **REW** button from stop mode.
 - The tape is rewound to the counter "0 00 00" reading.
 - If you rewind the tape past the "0 00 00" position, press the **FF** button.

NOTES:

- There is no tape counter indication for the blank portions of the tape
- There may be a slight discrepancy between the position shown on the tape counter and the actual tape position.
- When rewinding the tape past the "0 00 00" position, a minus (-) sign will be displayed.
- This VCR is equipped with a memory function that, while recording (or playback), will first store the pictures in the internal memory before it actually records them to tape (or outputs them to the screen). Therefore, during recording/playback, the tape counter will start and stop repeatedly.

DAY/TIME SEARCH

Day/Time Search

- 1 Press the **SEARCH** button three times during stop mode.

- "T/D SEARCH 01 00:00:00" will be displayed on screen.

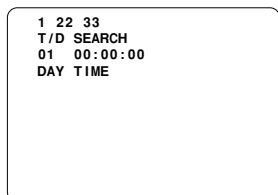

- 2 Press the **DATA** ▼ (or ▲) button to set the desired day, then press the **SHIFT** → button.
- 3 Press the **DATA** ▼ (or ▲) button to set the desired hour, then press the **SHIFT** → button.
- 4 Press the **DATA** ▼ (or ▲) button to set the desired minutes, then press the **SHIFT** → button.
- 5 Press the **DATA** ▼ (or ▲) button to set the desired seconds.
- 6 Press the **FF** (or **REW**) button.
 - Day/time search will start.
 - The desired day/time is searched and a still image will appear on-screen.
 - Depending on the recording speed mode, there may be no recording for the desired time. In such a case, playback will start when the search passes the desired time.
- 7 Press the **PLAY** button.
 - Playback will start.

NOTES:

- If during a search the end of the tape is reached, the tape will rewind and stop. If the beginning of the tape is reached, it will stop.
- The alarm and day/time data are recorded on the tape in a similar format. If they overlap, the alarm data will have the priority. Therefore, when searching for a day/time when an alarm recording was done, the day/time search will not stop at the desired location. In such a case, use alarm scan to find the desired recording location.
- The day/time search function may not operate correctly if searching for a timer recording time or if the clock on the recording VCR has been adjusted using the **CLOCK ADJUSTMENT** function.
- If the **FF** (or **REW**) button is pressed before the setting is completed, the search will be performed with all the other settings to the default values. (Example: If the **FF** (or **REW**) button is pressed after the hour is set (step 3), the search will start using "00" as the minutes and seconds setting.)
- If a recording on a tape extends for over a one month period, the same day may be present twice on the tape. If such a day is searched, since there is no month search setting, the desired day may not be found.
- If the recording has been made in 72-hour or more mode, the day/time search with a minutes and seconds setting (see steps 4 and 5) will not operate. When using the day/time search function on such a recording, set the minutes and seconds (see steps 4 and 5) to "00".

SETTING THE SECURITY LOCK

The security lock function is designed to prevent accidental stopping of recording if the **STOP** button is pressed inadvertently.

Setting the Security Lock

- ❶ Press the **MENU** button to display the (MAIN MENU 1) menu.
- ❷ Press the **SHIFT ↓** (or **↑**) button until the (MAIN MENU 2) menu is displayed.
- ❸ Press the **SHIFT ↓** (or **↑**) button to select the "4. SECURITY LOCK" line, then press the **MENU** button.
 - The (SECURITY LOCK) menu appears.

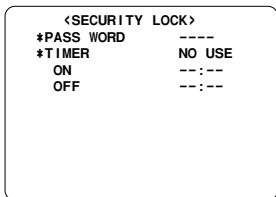

- ❹ Press the **DATA ▼** (or **▲**) and **SHIFT →** button, to set the 4 digit password.
 - DATA ▼** (or **▲**) button To select a digit
 - SHIFT →** button. To move to the right
 - If necessary, follow the steps below to set the timer ON/OFF times, and the security lock will only be active from the ON time to the OFF time.
- ❺ Press the **SHIFT ↓** button until the "TIMER" setting is flashing.
- ❻ Press the **DATA ▼** (or **▲**) button, to set the timer mode while the security lock is set.
 - NO USE The security lock is always on.
 - USE. The security lock will only be active from the ON time to the OFF time.
 - If the setting "USE" is selected, follow the steps below to set the timer on/off times.
- ❼ Press the **SHIFT ↓** button.
- ❽ Press the **DATA ▼** (or **▲**) button to set the timer on hour, then press the **SHIFT →** button.
- ❾ Press the **DATA ▼** (or **▲**) button to set the timer on minutes.
- ❿ Press the **SHIFT ↓** button, then press the **SHIFT →** button.
- ⓫ Follow steps ❸ and ❾ to set the timer off time.
- ⓬ Press the **MENU EXIT** or **MENU** button to save the settings and set the security lock on.
 - "1" is displayed on the digital display.

NOTES:

- After the setting has been made, "1" will be displayed from the security lock timer off time to the on time.
- During the security lock timer off period, "1" will be displayed and except for (SECURITY LOCK) menu changes all operations can be carried out.
- During the security lock timer on period, when a button is pressed the (SECURITY LOCK) menu is displayed. Except for security lock function cancel and cancel suspension (by pressing the **MENU EXIT** button) no other operation can be carried out.
- If the PASS WORD is lost or forgotten, please consult your dealer.
- The **REC** and **TIMER** buttons will operate for about 5 seconds immediately after the security lock is set. After that, all operation buttons will be disabled.

Cancel the Security Lock

- ❶ Press any button.
 - "----" is displayed on the digital display.
 - The (SECURITY LOCK) menu appears.
 - While the security lock timer is used, between the off time and the on time, display the (SECURITY LOCK) menu using the **MENU** and **SHIFT ↓** buttons.
- ❷ Press the **DATA ▼** (or **▲**) and **SHIFT →** button, to enter the 4 digit pass word.
 - DATA ▼** (or **▲**) button . To select a digit
 - SHIFT →** button To move to the right
- ❸ Press the **MENU EXIT** button.
 - The security lock is canceled and "1" will be erased.
 - The security lock timer set times are not erased.

Setting and Canceling the Quick Method Security Lock

- ❶ While holding the **SHIFT →** button, press the **REC/PLAY SPEED ▲** button.
 - "1" is displayed on the digital display.

To cancel the security lock, while holding the **SHIFT →** button, press the **REC/PLAY SPEED ▼** button, "1" will be erased from the digital display.

NOTE:

- It is not possible to set the security lock function and the quick method security lock function simultaneously.

SETTING THE BUZZER

A buzzer can be set to sound during alarm recording, if during recording the tape reaches the end, if buttons are pressed or if there is a mechanical failure that causes the tape to stop or be ejected, etc.

- ① Press the **MENU** button to display the (MAIN MENU 1) menu.
- ② Press the **SHIFT ↓** button to select the "3. BUZZER SET" line, then press the **MENU** button.
 - The (BUZZER SET) menu appears.

| <BUZZER SET> | |
|--------------|--------|
| *BUZZER | SET UP |
| ALARM IN | Y |
| TAPE END | Y |
| KEY IN | N |
| WARNING | Y |
| THREAD CHECK | Y |
| VIDEO LOSS | Y |
| NON REC | Y |
| CLOG DETECT. | Y |

- ③ Press the **DATA ▼** (or **▲**) button to select the desired mode.
 - SET UP To use a predetermined setting for each item
 - ALL OFF To set all items to "N"
 - If using the "SET UP" setting, continue with steps ④ and ⑤.
- ④ Press the **SHIFT ↓** button, until the desired item for which the buzzer function will be set is flashing.
- ⑤ Press the **DATA ▼** (or **▲**) button to set "Y" for the functions described below.

- ALARM IN The buzzer will be heard during alarm recording.
- TAPE END The buzzer will be heard when the end of the tape is reached during recording. To stop the buzzer, press the **STOP**, **EJECT**, **FF**, **REW** or **PLAY** button.
- KEY IN The buzzer will be heard when one of the VCR buttons is pressed.
- WARNING The buzzer will be heard if the tape stops or is ejected due to a problem with the internal mechanism. To stop the buzzer, press the **STOP** button.

- THREAD CHECK . . . The buzzer will be heard if the tape is not loaded properly.
 - VIDEO LOSS The buzzer will be heard if there is no video signal during recording.
 - NON REC The buzzer will be heard if during recording the VCR enters a mode other than recording.
 - CLOG DETECT The buzzer will be heard if the heads are dirty and recording quality deteriorate.
- ⑥ Press the **MENU EXIT** button to save the settings.

NOTES:

- If "N" is set, the buzzer will not be heard.
- During timer recording mode, security lock engaged mode and alarm recording mode, the buzzer will not be heard when a button related to one of these modes is pressed, even if "Y" is set for the "KEY IN" item.

CLOCK ADJUSTMENT

When using 2 or more VCRs of this same model, the clock on the second VCR and on, can be synchronized with the clock on the first VCR, using the CLOCK ADJUSTMENT function.

- ❶ Connect the **CLOCK SET OUT** terminal on VCR 1 to the **CLOCK SET IN** terminal on VCR 2.
- ❷ Repeat the procedure for all the other VCRs, connecting the **CLOCK SET OUT** terminal on VCR 2 to the **CLOCK SET IN** terminal on VCR 3, and so on.
- ❸ Press the **MENU** button to display the (MAIN MENU 1) menu.
- ❹ Press the **SHIFT ↓** button to select the "4. VARIOUS SET 1" line, then press the **MENU** button.
 - *The (VARIOUS SET 1) menu appears.*

```

<VARIOUS SET 1>
*THREAD CHECK      Y
*REMOTE            EJECT
*EXT TIME ADJ.     01:00
*TAPE END OUT      PRE
*EJECT SET
  EJECT MODE       EJECT1
  OPERATION        SLAVE
  
```

- ❺ Press the **SHIFT ↓** button, until the "EXT TIME ADJ." setting is flashing.
- ❻ Press the **DATA ▼** (or **▲**) button to set the hour at which the adjustment will be conducted.

NOTES:

- Be sure to set the same time on all the VCRs.
- The clock adjustment cannot be set to "00:00".

Example

```

<VARIOUS SET 1>
*THREAD CHECK      Y
*REMOTE            EJECT
*EXT TIME ADJ.     07:00
*TAPE END OUT      PRE
*EJECT SET
  EJECT MODE       EJECT1
  OPERATION        SLAVE
  
```

- ❼ Press the **MENU EXIT** button to save the setting.
 - *The setting procedure on the first VCR is now completed.*
- ❽ Repeat the procedure for all the other VCRs, setting "EXT TIME ADJ." (to the same time as set on the first VCR).

NOTES:

- Connect the **COM** terminal on all VCRs used.
- This function will not operate on the day the summer/standard time is changed.

SETTING THE CASSETTE EJECT MODE

Cassette Eject Setup

When using 2 VCRs or more, the cassette tape of all the VCRs or some of the VCRs can be ejected, if the **EJECT** terminals on the VCRs are connected as indicated.

- ❶ Press the **MENU** button to display the (MAIN MENU 1) menu.
- ❷ Press the **SHIFT ↓** button to select the "4. VARIOUS SET 1" line, then press the **MENU** button.
 - The (VARIOUS SET 1) menu appears.

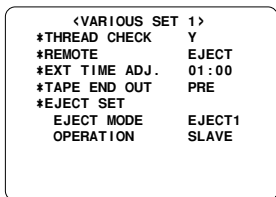

- ❸ Press the **SHIFT ↓** (or **↑**) button, until the "EJECT MODE" setting is flashing.
- ❹ Press the **DATA ▼** (or **▲**) button to set the desired cassette eject mode.
 - EJECT1 The cassette is ejected only if the VCR is not in recording mode.
 - EJECT2 The cassette is ejected only if the VCR is in stop mode.
- ❺ Press the **SHIFT ↓** button, until the "OPERATION" setting is flashing.
- ❻ Press the **DATA ▼** (or **▲**) button to set the desired operation.
 - SLAVE When the **EJECT** button is pressed, the cassette tape of that VCR only will be ejected.
 - MASTER When the **EJECT** button is pressed, the cassette tape of that VCR and of any VCR connected after it will be ejected.
- ❼ Press the **MENU EXIT** button to save the settings.

NOTE:

- The **EJECT** button will not be operative during recording mode.

EJECT terminal connection

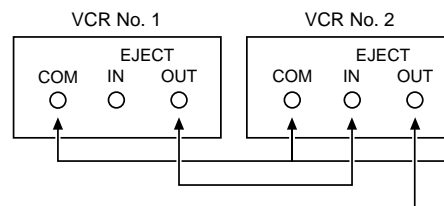

EJECT IN terminal

- Depending on the (VARIOUS SET 1) menu "EJECT MODE" setting (see "Cassette Eject Setup"), the cassette loaded in the VCR is ejected when there is an input at this terminal.

EJECT OUT terminal

- When the **EJECT** button is pressed (if the VCR is setup as "MASTER", see step ❻ under "Cassette Eject Setup") or when there is an input (trigger) at the **EJECT IN** terminal, a signal is output at this terminal, even if the security lock is set or if a cassette is not loaded.

SETUP FOR RS-232C OR RS-485 USE

The VCR can be controlled by a computer connected to the RS-232C connector. It can also be controlled through a special controller connected to the RS-485 connector.

You must specify which connector (RS-232C or RS-485) is used. (Refer to "DIP Switches Setup")

DIP Switches Setup

The **DIP** switches need to be set when a computer, special controller, etc. connected to the RS-232C or RS-485 connectors is used to control the VCR. Make sure to turn the VCR power off before setting the **DIP** switches.

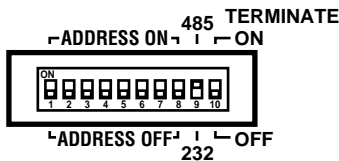

SW No.

1-7: To setup the VCR address (only when using the RS-485 connector).

Please refer to the chart for each address (0 to 127) DIP switches settings.

- Switch 1 is the least significant bit (LSB) and switch 7 the most significant bit (MSB) (Down: 0, Up: 1)

Example:

- If the address is 1, set switch 1 to the ON side (up)
- If the address is 10, set switches 2 and 4 to the ON side (up)
- If the address is 127, set all the switches to the ON side (up)

8: Available (Not used)

9: To select the connector used. [232] side (down) for RS-232C, [485] side (up) for RS-485.

10: To setup the termination (only when using the RS-485 connector).

OFF side (down): Not terminated

ON side (up): Terminated

NOTE:

- Refer to the RS-232C and RS-485 command section or to the special controller and/or to the computer instruction manual.

| Address | DIP switch (1:ON side, 0:OFF side) | | | | | | |
|---------|---------------------------------------|---|---|---|---|---|---|
| | 1 | 2 | 3 | 4 | 5 | 6 | 7 |
| 0 | 0 | 0 | 0 | 0 | 0 | 0 | 0 |
| 1 | 1 | 0 | 0 | 0 | 0 | 0 | 0 |
| 2 | 0 | 1 | 0 | 0 | 0 | 0 | 0 |
| 3 | 1 | 1 | 0 | 0 | 0 | 0 | 0 |
| 4 | 0 | 0 | 1 | 0 | 0 | 0 | 0 |
| 5 | 1 | 0 | 1 | 0 | 0 | 0 | 0 |
| 6 | 0 | 1 | 1 | 0 | 0 | 0 | 0 |
| 7 | 1 | 1 | 1 | 0 | 0 | 0 | 0 |
| 8 | 0 | 0 | 0 | 1 | 0 | 0 | 0 |
| 9 | 1 | 0 | 0 | 1 | 0 | 0 | 0 |
| 10 | 0 | 1 | 0 | 1 | 0 | 0 | 0 |
| 11 | 1 | 1 | 0 | 1 | 0 | 0 | 0 |
| 12 | 0 | 0 | 1 | 1 | 0 | 0 | 0 |
| 13 | 1 | 0 | 1 | 1 | 0 | 0 | 0 |
| 14 | 0 | 1 | 1 | 1 | 0 | 0 | 0 |
| 15 | 1 | 1 | 1 | 1 | 0 | 0 | 0 |
| 16 | 0 | 0 | 0 | 0 | 1 | 0 | 0 |
| 17 | 1 | 0 | 0 | 0 | 1 | 0 | 0 |
| 18 | 0 | 1 | 0 | 0 | 1 | 0 | 0 |
| 19 | 1 | 1 | 0 | 0 | 1 | 0 | 0 |
| 20 | 0 | 0 | 1 | 0 | 1 | 0 | 0 |
| 21 | 1 | 0 | 1 | 0 | 1 | 0 | 0 |
| 22 | 0 | 1 | 1 | 0 | 1 | 0 | 0 |
| 23 | 1 | 1 | 1 | 0 | 1 | 0 | 0 |
| 24 | 0 | 0 | 0 | 1 | 1 | 0 | 0 |
| 25 | 1 | 0 | 0 | 1 | 1 | 0 | 0 |
| 26 | 0 | 1 | 0 | 1 | 1 | 0 | 0 |
| 27 | 1 | 1 | 0 | 1 | 1 | 0 | 0 |
| 28 | 0 | 0 | 1 | 1 | 1 | 0 | 0 |
| 29 | 1 | 0 | 1 | 1 | 1 | 0 | 0 |
| 30 | 0 | 1 | 1 | 1 | 1 | 0 | 0 |
| 31 | 1 | 1 | 1 | 1 | 1 | 0 | 0 |
| 32 | 0 | 0 | 0 | 0 | 0 | 1 | 0 |
| 33 | 1 | 0 | 0 | 0 | 0 | 1 | 0 |
| 34 | 0 | 1 | 0 | 0 | 0 | 1 | 0 |
| 35 | 1 | 1 | 0 | 0 | 0 | 1 | 0 |
| 36 | 0 | 0 | 1 | 0 | 0 | 1 | 0 |
| 37 | 1 | 0 | 1 | 0 | 0 | 1 | 0 |
| 38 | 0 | 1 | 1 | 0 | 0 | 1 | 0 |
| 39 | 1 | 1 | 1 | 0 | 0 | 1 | 0 |
| 40 | 0 | 0 | 0 | 1 | 0 | 1 | 0 |
| 41 | 1 | 0 | 0 | 1 | 0 | 1 | 0 |
| 42 | 0 | 1 | 0 | 1 | 0 | 1 | 0 |
| 43 | 1 | 1 | 0 | 1 | 0 | 1 | 0 |
| 44 | 0 | 0 | 1 | 1 | 0 | 1 | 0 |
| 45 | 1 | 0 | 1 | 1 | 0 | 1 | 0 |
| 46 | 0 | 1 | 1 | 1 | 0 | 1 | 0 |
| 47 | 1 | 1 | 1 | 1 | 0 | 1 | 0 |
| 48 | 0 | 0 | 0 | 0 | 1 | 1 | 0 |
| 49 | 1 | 0 | 0 | 0 | 1 | 1 | 0 |
| 50 | 0 | 1 | 0 | 0 | 1 | 1 | 0 |
| 51 | 1 | 1 | 0 | 0 | 1 | 1 | 0 |
| 52 | 0 | 0 | 1 | 0 | 1 | 1 | 0 |
| 53 | 1 | 0 | 1 | 0 | 1 | 1 | 0 |
| 54 | 0 | 1 | 1 | 0 | 1 | 1 | 0 |
| 55 | 1 | 1 | 1 | 0 | 1 | 1 | 0 |
| 56 | 0 | 0 | 0 | 1 | 1 | 1 | 0 |
| 57 | 1 | 0 | 0 | 1 | 1 | 1 | 0 |
| 58 | 0 | 1 | 0 | 1 | 1 | 1 | 0 |
| 59 | 1 | 1 | 0 | 1 | 1 | 1 | 0 |
| 60 | 0 | 0 | 1 | 1 | 1 | 1 | 0 |
| 61 | 1 | 0 | 1 | 1 | 1 | 1 | 0 |
| 62 | 0 | 1 | 1 | 1 | 1 | 1 | 0 |
| 63 | 1 | 1 | 1 | 1 | 1 | 1 | 0 |

| Address | DIP switch (1:ON side, 0:OFF side) | | | | | | |
|---------|---------------------------------------|---|---|---|---|---|---|
| | 1 | 2 | 3 | 4 | 5 | 6 | 7 |
| 64 | 0 | 0 | 0 | 0 | 0 | 0 | 1 |
| 65 | 1 | 0 | 0 | 0 | 0 | 0 | 1 |
| 66 | 0 | 1 | 0 | 0 | 0 | 0 | 1 |
| 67 | 1 | 1 | 0 | 0 | 0 | 0 | 1 |
| 68 | 0 | 0 | 1 | 0 | 0 | 0 | 1 |
| 69 | 1 | 0 | 1 | 0 | 0 | 0 | 1 |
| 70 | 0 | 1 | 1 | 0 | 0 | 0 | 1 |
| 71 | 1 | 1 | 1 | 0 | 0 | 0 | 1 |
| 72 | 0 | 0 | 0 | 1 | 0 | 0 | 1 |
| 73 | 1 | 0 | 0 | 1 | 0 | 0 | 1 |
| 74 | 0 | 1 | 0 | 1 | 0 | 0 | 1 |
| 75 | 1 | 1 | 0 | 1 | 0 | 0 | 1 |
| 76 | 0 | 0 | 1 | 1 | 0 | 0 | 1 |
| 77 | 1 | 0 | 1 | 1 | 0 | 0 | 1 |
| 78 | 0 | 1 | 1 | 1 | 0 | 0 | 1 |
| 79 | 1 | 1 | 1 | 1 | 0 | 0 | 1 |
| 80 | 0 | 0 | 0 | 0 | 1 | 0 | 1 |
| 81 | 1 | 0 | 0 | 0 | 1 | 0 | 1 |
| 82 | 0 | 1 | 0 | 0 | 1 | 0 | 1 |
| 83 | 1 | 1 | 0 | 0 | 1 | 0 | 1 |
| 84 | 0 | 0 | 1 | 0 | 1 | 0 | 1 |
| 85 | 1 | 0 | 1 | 0 | 1 | 0 | 1 |
| 86 | 0 | 1 | 1 | 0 | 1 | 0 | 1 |
| 87 | 1 | 1 | 1 | 0 | 1 | 0 | 1 |
| 88 | 0 | 0 | 0 | 1 | 1 | 0 | 1 |
| 89 | 1 | 0 | 0 | 1 | 1 | 0 | 1 |
| 90 | 0 | 1 | 0 | 1 | 1 | 0 | 1 |
| 91 | 1 | 1 | 0 | 1 | 1 | 0 | 1 |
| 92 | 0 | 0 | 1 | 1 | 1 | 0 | 1 |
| 93 | 1 | 0 | 1 | 1 | 1 | 0 | 1 |
| 94 | 0 | 1 | 1 | 1 | 1 | 0 | 1 |
| 95 | 1 | 1 | 1 | 1 | 1 | 0 | 1 |
| 96 | 0 | 0 | 0 | 0 | 0 | 1 | 1 |
| 97 | 1 | 0 | 0 | 0 | 0 | 1 | 1 |
| 98 | 0 | 1 | 0 | 0 | 0 | 1 | 1 |
| 99 | 1 | 1 | 0 | 0 | 0 | 1 | 1 |
| 100 | 0 | 0 | 1 | 0 | 0 | 1 | 1 |
| 101 | 1 | 0 | 1 | 0 | 0 | 1 | 1 |
| 102 | 0 | 1 | 1 | 0 | 0 | 1 | 1 |
| 103 | 1 | 1 | 1 | 0 | 0 | 1 | 1 |
| 104 | 0 | 0 | 0 | 1 | 0 | 1 | 1 |
| 105 | 1 | 0 | 0 | 1 | 0 | 1 | 1 |
| 106 | 0 | 1 | 0 | 1 | 0 | 1 | 1 |
| 107 | 1 | 1 | 0 | 1 | 0 | 1 | 1 |
| 108 | 0 | 0 | 1 | 1 | 0 | 1 | 1 |
| 109 | 1 | 0 | 1 | 1 | 0 | 1 | 1 |
| 110 | 0 | 1 | 1 | 1 | 0 | 1 | 1 |
| 111 | 1 | 1 | 1 | 1 | 0 | 1 | 1 |
| 112 | 0 | 0 | 0 | 0 | 1 | 1 | 1 |
| 113 | 1 | 0 | 0 | 0 | 1 | 1 | 1 |
| 114 | 0 | 1 | 0 | 0 | 1 | 1 | 1 |
| 115 | 1 | 1 | 0 | 0 | 1 | 1 | 1 |
| 116 | 0 | 0 | 1 | 0 | 1 | 1 | 1 |
| 117 | 1 | 0 | 1 | 0 | 1 | 1 | 1 |
| 118 | 0 | 1 | 1 | 0 | 1 | 1 | 1 |
| 119 | 1 | 1 | 1 | 0 | 1 | 1 | 1 |
| 120 | 0 | 0 | 0 | 1 | 1 | 1 | 1 |
| 121 | 1 | 0 | 0 | 1 | 1 | 1 | 1 |
| 122 | 0 | 1 | 0 | 1 | 1 | 1 | 1 |
| 123 | 1 | 1 | 0 | 1 | 1 | 1 | 1 |
| 124 | 0 | 0 | 1 | 1 | 1 | 1 | 1 |
| 125 | 1 | 0 | 1 | 1 | 1 | 1 | 1 |
| 126 | 0 | 1 | 1 | 1 | 1 | 1 | 1 |
| 127 | 1 | 1 | 1 | 1 | 1 | 1 | 1 |

SETUP FOR RS-232C OR RS-485 USE

Setup for RS-232C or RS-485 Use

- ❶ Press the **MENU** button to display the (MAIN MENU 1) menu.
- ❷ Press the **SHIFT ↓** (or **↑**) button until the (MAIN MENU 2) menu is displayed.
- ❸ Press the **SHIFT ↓** (or **↑**) button to select the "1. RS-485 SET (or RS-232C SET)" line, then press the **MENU** button.

- The (RS-485 SET (or RS-232C SET)) menu appears.

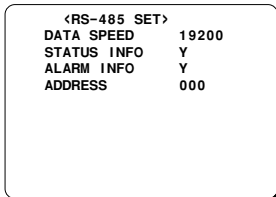

- The menu name will depend on the DIP switch 9 setting. When down (RS-232C SET) is displayed and when up (RS-485 SET) is displayed.
- The STATUS INFO, ALARM INFO and ADDRESS lines are only displayed when DIP switch 9 is set to 485.
- The "ADDRESS" line will display the setting entered using the DIP switches on the VCR back panel (the setting cannot be modified from within the menu).

- ❹ Press the **DATA ▼** (or **▲**) button to set the desired transfer speed.

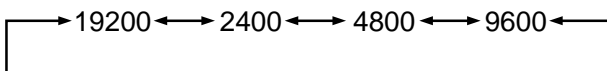

- ❺ Press the **SHIFT ↓** button, until the "STATUS INFO" setting is flashing.
- ❻ Press the **DATA ▼** (or **▲**) button to set the desired setting.

- Y The VCR status information (state information and warning state) and mode changes are output at the RS-485 connector.
- N The VCR status information (state information and warning state) and mode changes are not output at the RS-485 connector.

- ❼ Press the **SHIFT ↓** button, until the "ALARM INFO" setting is flashing.

- ❽ Press the **DATA ▼** (or **▲**) button to set the desired setting.

Y The VCR alarm information (alarm recording start and stop) and video loss information are output at the RS-485 connector.

N The VCR alarm information (alarm recording start and stop) and video loss information are not output at the RS-485 connector.

- ❾ Press the **MENU EXIT** button to save the setting.

RS-485 RJ-11 connector layout

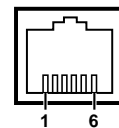

NOTE: Do not connect to phone line.

| Pin number | Connector A signal | Connector B signal |
|------------|--------------------|--------------------|
| 1 | Not used | Not used |
| 2 | Not used | Not used |
| 3 | A | B |
| 4 | B | A |
| 5 | Not used | Not used |
| 6 | Not used | Not used |

A: Non-inverting driver output/receiver input

B: Inverting driver output/receiver input

RS-485 Connection

This VCR can use the straight type or crossed type connecting cables.

If using a straight type cable, connect it from the "A" to the "A" or from the "B" to the "B" RS-485 connector.

If using a crossed type cable, connect it from the "A" to the "B" or from the "B" to the "A" RS-485 connector.

Types of cables

Straight type: A cable with pin connection number correspondence (e.g. pin 1 to pin 1, pin 2 to pin 2, etc.).

Crossed type: A cable without pin connection number correspondence.

SETUP FOR RS-232C OR RS-485 USE

RS-232C 9-pin connector layout

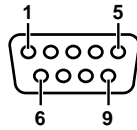

| Pin number | Signal | Operation | Signal direction |
|------------|--------|-----------------|------------------|
| 2 | RXD | Receive data | VCR ← Computer |
| 3 | TXD | Send data | VCR → Computer |
| 7 | RTS | Request to send | VCR → Computer |
| 5 | GND | Signal ground | |

The signal transmission is compatible with RS-232C specifications.

CHECKING POWER FAILURE, FAILURE DUE TO CONDENSATION AND USAGE DURATION

- ❶ Press the **MENU** button to display the (MAIN MENU 1) menu.
- ❷ Press the **SHIFT ↓** (or **↑**) button until the (MAIN MENU 2) menu is displayed.
- ❸ Press the **SHIFT ↓** (or **↑**) button to select the “3. POWER/DEW/USED TIME” line, then press the **MENU** button.
 - The (POWER/DEW/USED TIME) menu appears.

- ❹ Press the **MENU EXIT** button, the normal screen is displayed.

NOTE:

- If the **MENU RESET** button is pressed while the “POWER FAILURE” and “DEW” data is displayed, the data is erased. The “USED TIME” data cannot be reset. “P” will be erased from the digital display.

Example

| | |
|-----------------|-------------|
| <POWER FAILURE> | |
| 002 FAILURE | 25-12 07:15 |
| RECOVERY | 25-12 07:30 |
| <DEW> | |
| 001 FAILURE | 25-12 11:00 |
| RECOVERY | 25-12 12:00 |
| <USED TIME> | |
| VIDEO | 00003H |
| POWER | 00007H |

- POWER FAILURE . . . The number of power failures, and the date and time of the most recent power failure and recovery are displayed.
- DEW The number of failures due to condensation, and the date and time of the most recent failure and recovery are displayed.
- USED TIME The video heads usage duration and the power on duration are displayed.

OUTPUT TERMINALS

TAPE END OUT Terminal

- During recording, when the end of the tape is reached or when approximately 5% of the tape remains, the output becomes 0V (Low).
- To reset the output, press the **STOP** or **EJECT** button.
- During autorepeat recording, when the end of the tape is reached, the output becomes 0V (Low) for about 2 seconds only.

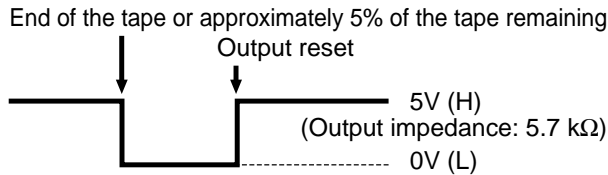

TAPE END OUT Terminal Output Setting

- 1 Press the **MENU** button to display the (MAIN MENU 1) menu.
- 2 Press the **SHIFT ↓** button to select the "4. VARIOUS SET 1" line, then press the **MENU** button.
 - The (VARIOUS SET 1) menu appears.

| <VARIOUS SET 1> | |
|-----------------|--------|
| *THREAD CHECK | Y |
| *REMOTE | EJECT |
| *EXT TIME ADJ. | 01:00 |
| *TAPE END OUT | PRE |
| *EJECT SET | |
| EJECT MODE | EJECT1 |
| OPERATION | SLAVE |

- 3 Press the **SHIFT ↓** (or **↑**) button, until the "TAPE END OUT" setting is flashing.
- 4 Press the **DATA ▼** (or **▲**) button to select the desired output mode.
 - PRE The output becomes 0 V (Low) when approximately 5% of the tape remains (if recording has been started at the beginning of the tape) and/or when the end of the tape is reached (if recording has not been started at the beginning of the tape).
 - END The output becomes 0 V (Low) when the tape reaches the end.
- 5 Press the **MENU EXIT** button to save the setting.

WARNING OUT Terminal

- If the tape stops or other problem (the heads are dirty, there is a problem with the battery or the cooling fan, etc.) the output becomes 0V (Low).
- To reset the output, press the **STOP** or **ALL RESET** button or unplug the power cord then plug it back in.

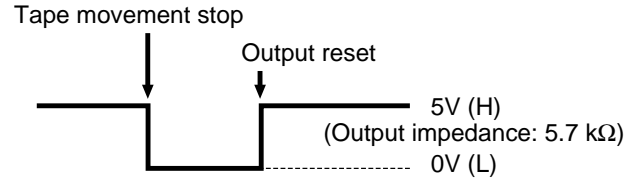

NOTE:

- If the output is 0V (Low) due to the clog detect function, it can be reset by simply pressing the **STOP** button.

TIMER OUT Terminal

- During timer recording DC 12 V (High) are output. (During timer recording stand-by mode, the output is 0V (Low).)

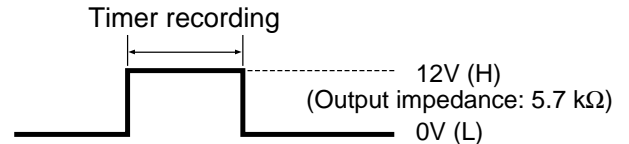

COM Terminal

- Common GND (ground) terminal when connecting other terminals to external devices.

SW OUT Terminal

When recording, a pulse signal is output at the **SW OUT** terminal.

This terminal is usually connected to the switch input (SW IN) of devices like a camera switcher unit, or a quad compressor.

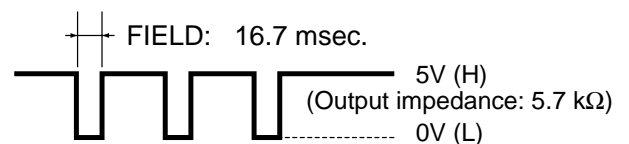

OUTPUT TERMINALS

REMOTE Jack

You can use a VA-RMN01 Remote Control Unit (sold separately) to control remotely the VCR.

NOTE:

- The functions not available on the VCR will not operate.

Remote control of the VCR is possible by connecting a remote controller with a circuit such as indicated below, to the **REMOTE** jack.

NOTES:

- Use a 3.5 mm mini-jack type plug.
- The connection should be done using a shielded cable no more than 5 meters long.
- The functions not available on the VCR will not operate.

Remote control circuit

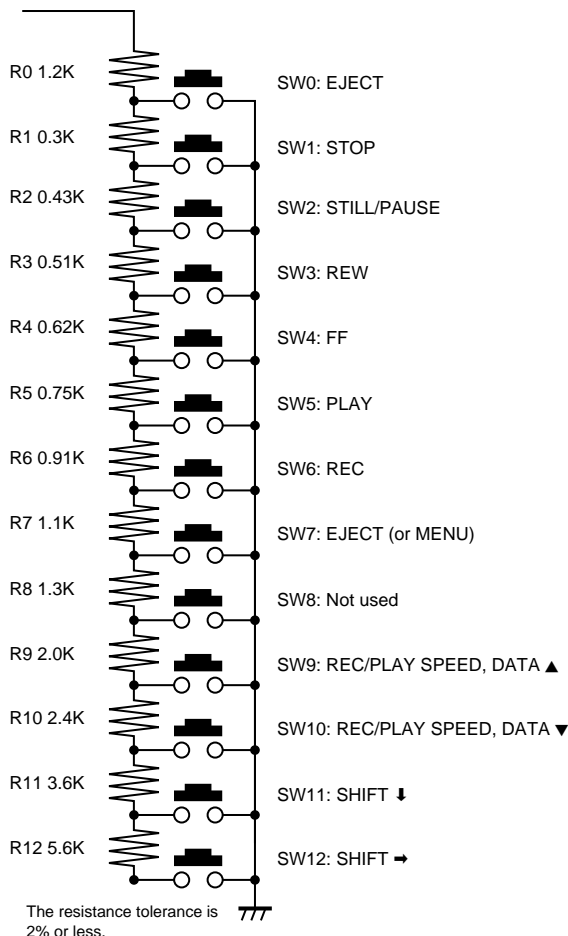

Remote control setting

The remote control switch 7 can be set to either eject the tape or access the menus.

- 1 Press the **MENU** button to display the (MAIN MENU 1) menu.
- 2 Press the **SHIFT ↓** button to select the "4. VARIOUS SET 1" line, then press the **MENU** button.
 - The (VARIOUS SET 1) menu appears.

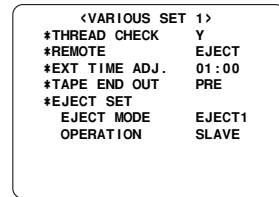

- 3 Press the **SHIFT ↓** button, until the "REMOTE" setting is flashing.
- 4 Press the **DATA ▼** (or **▲**) button to select the desired switch mode.
 - EJECT Switch 7 will eject the tape.
 - MENU Switch 7 will display the menu.
- 5 Press the **MENU EXIT** button to save the setting.

NON REC OUT terminal

If during recording the VCR enters a mode other than recording (i.e. recording pause, stop mode, etc.), a LOW signal (0 V) is output. If recording is resumed, then a HIGH signal (5 V) is output.

If in the (BUZZER SET) menu, NON REC is set to "Y", a buzzer will be heard while the VCR is in non recording mode. The buzzer will stop if the **STOP** button is pressed (the output signal will remain LOW (0 V)).

MAINTENANCE

Daily Inspection

The following daily inspections are recommended in order to assure long-term and trouble-free operation of the unit.

The daily inspections are particularly important if using autorepeat recording.

Inspection Procedure

- ❶ Turn on the power to the VCR, camera, TV monitor and other connected devices.
- ❷ Check that the image received on the TV monitor is correct.
- ❸ Check that the on-screen display of the date and time is correct.
- ❹ To check the recording condition of the previous day, rewind the recorded tape a few seconds.
- ❺ Press the **PLAY** button and check that the playback image is correct.
- ❻ Check that the recorded date and time are correct.

NOTES:

- If the security lock is engaged, it has to be released before proceeding to the inspection.
- If any problem is discovered during the inspection, unplug the power cord then consult your dealer.

Periodic Inspection

Periodic inspection and maintenance should be referred to your dealer.

If the playback picture is not clear, and it cannot be corrected using the tracking control, it may indicate that the video heads need cleaning.

The video heads should be inspected every 1,000 hours of use to determine if they need to be replaced.

The video heads usage can be checked using the (POWER/DEW/USED TIME) menu.

Cabinet Cleaning

Clean the outside of the cabinet with a clean, soft cloth, moistened with lukewarm water and wrung dry.

DO NOT USE SOLVENTS OR OTHER TYPES OF CLEANERS. THESE CHEMICALS CAN CRACK OR DISCOLOUR THE CABINET.

About the Backup Lithium Battery

The date and time settings are maintained for up to 30 days by a rechargeable lithium battery that is fully charged after the VCR has been connected to a power source for 48 hours or more.

Depending on the battery usage it may become necessary to change it. For replacement and disposal of the old battery, please contact your dealer.

After the battery has been replaced, press the **ALL RESET** button, then enter all the time, date, etc. settings as required.

MAINTENANCE

Maintaining and Checking The Mechanism

To maintain the VCR functions and features working properly, and to avoid damages or dirt on the tape, it is recommended to follow the maintenance points and periodicity indicated below.

For detailed information, please contact your dealer.

Maintenance Table

○ : Cleaning ◎ : Confirmation △ : Lubrication □ : Change

| | PARTS | 2000H | 4000H | 6000H | 8000H | NOTES |
|----------------------|--------------------------------|-------|-------|-------|-------|----------------------------------|
| Tape Path System | ASSY, BRAKE BAND | ◎ | □ | ◎ | □ | |
| | ASSY, LEVER BT (tape guide) | ○ | ○ | ○ | ○ | |
| | FULL ERASE HEAD | ○ | ○ | ○ | □ | |
| | ASSY, ROLLER CLEANER | ◎ | □ | ◎ | □ | |
| | ASSY, GUIDE ROLLER | ○ | ○ | ○ | ○ | |
| | ASSY, MOUNTING INCLNE S | ○ | ○ | ○ | □ | |
| | ASSY, MOUNTING INCLNE T | ○ | ○ | ○ | □ | |
| | ACE HEAD | ○ | ○ | ○ | □ | |
| | ASSY, LEVER PINCH ROLLER | ○ | □ | ○ | □ | |
| | MOUNTING, LIFT PINCH | | | | □ | |
| | CAM, LIFT PINCH | | | | □ | |
| | GEAR, CAM PINCH | | | | □ | |
| | ASSY, EARTH CYL | | □ | | □ | |
| | COMPL, CYLINDER | ○ | ○(□) | ○ | ○(□) | |
| ASSY, CYLINDER UPPER | ○(□) | ○(□) | ○(□) | ○(□) | | |
| Reel Drive System | ASSY, REEL SUPPLY | ○△ | ○△ | ○△ | ○△ | |
| | ASSY, REEL TAKEUP | ○△ | ○△ | ○△ | ○△ | |
| | GEAR, REEL S | △ | △ | △ | △ | |
| | GEAR, REEL T | △ | △ | △ | △ | |
| | PULLEY, REEL | △ | △ | △ | △ | |
| | SPECIAL, WASHER 2.4 X 6 X 0.25 | | ◎ | | ◎ | |
| | COMPL, MOUNTING CLUTCH | △ | □ | △ | □ | |
| | BELT, REEL | ◎ | □ | | □ | |
| | MOTOR, CAPSTAN | ○ | ◎(□) | ◎(□) | □ | |
| | ASSY, GEAR FRICTION | △ | △□ | △ | △□ | |
| Brake | ASSY, BRAKE S | ◎ | ◎ | ◎ | ◎ | |
| | ASSY, BRAKE T | ◎ | ◎ | ◎ | ◎ | |
| | ASSY, BRAKE CAPSTAN | ◎ | ◎ | ◎ | ◎ | |
| | ASSY, BRAKE SOFT T | | ◎ | | □ | |
| Loading Drive System | ASSY, LOADING MOTOR | | ◎ | | □ | |
| | DAMPER | | | | □ | |
| | COMPL, GEAR WORM | | ◎ | | □ | |
| | CAM, MAIN | | | | □ | |
| | SPECIAL WASHER 3.6 X 0.5 | | ◎ | | □ | |
| | GEAR, WHEEL 1 | | | | □ | |
| | GEAR, WHEEL 2 | | ◎ | | □ | |
| | MODE SWITCH | | ◎ | | □ | |
| | SLIDE, CRECENT | | ◎ | | □ | |
| | GEAR, LOAD S | | ◎ | | □ | |
| | GEAR, RACK FRONT | | ◎ | | □ | |
| GEAR, RACK START | | ◎ | | □ | | |
| GEAR, PINON | | ◎ | | □ | | |
| Performance Check | BACK TENSION TORQUE | ◎ | ◎ | ◎ | ◎ | PB BACK TENSION TORQUE 25~50g.cm |
| | FWD, REW TORQUE | ◎ | ◎ | ◎ | ◎ | FWD, REW TORQUE ≥ 600g.cm |
| | PLAY TORQUE | ◎ | ◎ | ◎ | ◎ | PLAY 55 ~ 110g.cm |
| | REV TORQUE | ◎ | ◎ | ◎ | ◎ | REV 100 ~ 210g.cm |

NOTE:

1. This table shows the maintenance for up to 8000 hours. After this, repeat from the start of the table.
2. For places with symbols such as ◎ (□) and ○ (□), carry out checking and cleaning, and replace if necessary.
3. This periodic maintenance check table changes considerably according to the using conditions and environment.
4. Refer to (POWER/DEW/USED TIME) menu for the length of time the unit has been used.
5. As life may be shortened if foreign particles and dusts remain accumulated on the tape guides and rotating and contacting portions, clean if dirty.
6. Dusts and other foreign particles on the tape guides may also shorten the tape life and lower picture quality, therefore clean thoroughly.

TROUBLESHOOTING GUIDE

If the unit does not operate normally when you follow the instructions indicated in the manual, please refer to the table below.

| SYMPTOM | POSSIBLE CAUSE | CORRECTIVE ACTION |
|--|--|---|
| No power | The power cord is not connected | Connect the power cord |
| No image displayed on the monitor TV | The connections are not correct | Check that all connections are correct |
| | The power to the camera and/or monitor TV is not turned on | Turn all connected devices power on |
| The buttons do not respond | A cassette tape is not loaded | Load a cassette and turn the power on |
| | All functions are suspended due to condensation | Wait for the "ddd" indicator to go off |
| | Alarm recording | Wait for the alarm recording to end |
| | The security lock is engaged | Cancel the security lock |
| Recording is not possible (the tape is ejected) | The loaded cassette has no erasure-prevention tab | Load a cassette tape with erasure-prevention tab or cover the tab hole with adhesive tape |
| Autorepeat recording is not possible | "A" is displayed on the digital display | Display (ALARM LOG) menu, then press the MENU RESET button to turn off the "A" indicator |
| Timer recording is not possible | The date and time are not set correctly | Set the date and time correctly |
| | The unit is not set to timer recording stand-by mode | Press the TIMER button to display "□" on the digital display |
| | "N" is selected for the timer recordings | Be sure to select "Y" for the programmed timer recordings |
| Alarm recording is not possible | "OFF" is displayed on the digital display | Press the EJECT , STOP , FF , REW or PLAY button to turn the indicator off |
| Playback picture is not clear | The video heads need cleaning | Clean the video heads |
| The cassette tape cannot be ejected | Problem with the system | Unplug the power cord then plug it back in |
| The cassette is ejected a few seconds after it has been inserted | The tape is not threaded correctly | Try inserting the cassette one more time or using a new cassette. If it is ejected again, please consult your dealer. |

After a Power Failure

If after a power failure the recording speed is reset to 12-hour mode, it is due to insufficient backup battery charge. This is not a malfunction.

System Down

If the unit does not function at all, try the following.

- ❶ Unplug the power cord then plug it back in.
- ❷ Reset the memory. (Press the **ALL RESET** button. Under normal conditions, do not touch the **ALL RESET** button.)

NOTE:

- The time and date will be reset, and the quick method security lock will be cancelled. The (SECURITY LOCK) menu data cannot be reset.
- ❸ If the problem is not corrected after performing steps ❶ and ❷ a few times, consult your dealer.

SPECIFICATIONS

General Specifications

| | |
|------------------------------------|---|
| Recording method | 2-head rotating helical scanning system |
| Playback method | 2-head rotating helical scanning system |
| Audio recording | In 12-, 24-, 48- and 72-hour modes |
| Tape speed | 13.9 mm /sec |
| Specified video cassette tape | 1/2 S-VHS ST-180XZES cassette tape |
| Recording/playback time | 12, 24, 48, 72, 96, 120, 168, 240, 360, 480, 720 and 960 hours (when using ST-180XZES tape) |
| Fast forward/rewind time | approximately 3 minutes (when using ST-180XZES tape) |
| Television system | PAL colour TV system |
| RS-232C/RS-485 data transfer speed | 19200, 9600, 4800, 2400 baud |

Video

| | |
|-----------------------|---|
| Video input | 1 V(p-p), BNC, 75 Ω , unbalanced |
| Video output | 1 V(p-p), BNC, 75 Ω , unbalanced |
| S-video input | Separate YC signal, DIN connector |
| S-video output | Separate YC signal, DIN connector |
| Horizontal resolution | Black & white mode 520 line or more Colour mode 520 line or more |

Audio

| | |
|------------------|---|
| Input | -8 dBs, RCA pin jack, 27 k Ω , unbalanced |
| Output | -8 dBs, RCA pin jack, 600 Ω , unbalanced |
| Microphone input | -60 dBs, 3.5 mm mini jack, 10 k Ω , unbalanced |

Connectors

| | |
|---------------------------|--|
| Alarm input | Low level active (0V 100msec or more) |
| Alarm output | DC 5 V (± 0.5)/5.7 k Ω , Low at alarm |
| Alarm reset input | Low level active (0V 100msec or more) |
| Switch output | DC 5 V (± 0.5)/5.7 k Ω , Low at switching |
| Tape end output | DC 5 V (± 0.5)/5.7 k Ω , Low at tape end |
| Warning output | DC 5 V (± 0.5)/5.7 k Ω , Low at warning |
| Ext timer input | Low level active (0V 100msec or more) |
| Timer output | DC 12 V (± 0.5)/5.7 k Ω , High at timer recording |
| Non recording output | DC 5 V (± 0.5)/5.7 k Ω , Low at non recording |
| Video loss output | DC 5 V (± 0.5)/5.7 k Ω , Low at no video signal |
| Series input | Low level active (0V 500msec or more) |
| Series output | DC 5 V (± 0.5)/5.7 k Ω |
| Clock set input | Low level active (0V 100msec or more) |
| Clock set output | DC 5 V (± 0.5)/5.7 k Ω , Low at clock set in |
| Eject input | Low level active (0V 100msec or more) |
| Eject output | DC 5 V (± 0.5)/5.7 k Ω |
| Trigger shot record input | Low level active (0V 100msec or more) |
| Common | 0 V (GND) |
| Remote control input | 3.5 mm mini jack |

Other Specifications

| | |
|-----------------------------|--------------------------------|
| Operating temperature range | 5°C to 40°C |
| Operating humidity range | 80% or less |
| Power requirements | 220-240 V AC, 50/60 Hz |
| Power consumption | 24 W |
| Dimensions | 420 (W) x 142 (H) x 299 (D) mm |
| Weight | approximately 6.8 kg |

NOTE: The specifications and external appearance of this unit are subject to change without notice.



SANYO Electric Co., Ltd.

1AC6P1P2316--B
RD2QD/EX
(0900KP-SY01)

Issue No. 3

Copyright SANYO, 2000 All rights reserved.

Printed in Japan