

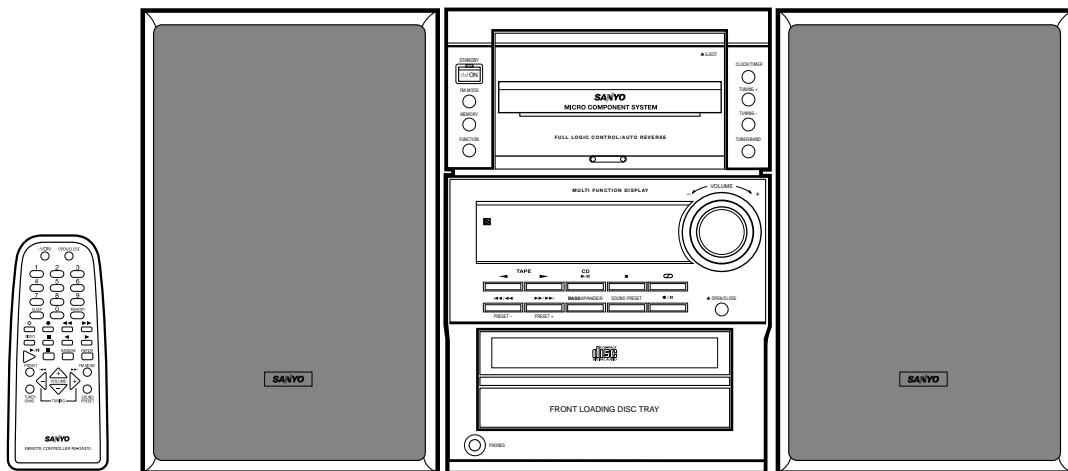

INSTRUCTION MANUAL

DC-DA3000

Micro Component System



PRECAUTIONS

CLASS 1 LASER PRODUCT
LUOKAN 1 LASERLAITE
KLASS 1 LASERAPPARAT

CAUTION – INVISIBLE LASER RADIATION WHEN OPEN AND INTERLOCKS DEFEATED. AVOID EXPOSURE TO BEAM.

ADVARSEL – USYNLIG LASER STRÅLING VED ÅBNING, NÅR SIKKERHEDSAFBRYDERE ER UDE AF FUNKTION, UNDGÅ UDSÆTTELSE FOR STRÅLING.

VARNING – OSYNLIG LASER STRÅLNING NÅR DENNA DEL ÄR ÖPPNAD OCH SPÄRR ÄR URKOPPLAD. STRÅLEN ÄR FARLIG.

VORSICHT – UNSICHTBARE LASERSTRAHLUNG TRITTS AUS, WENN DECKEL GEÖFFNET UND WENN SICHERHEITVERRIEGELUNG ÜBERBRÜCKT IST. NICHT, DEM STRAHL AUSSETZEN.

VARO – AVATTAESSA JA SUOJALUKITUS OHITETTAESSA OLET ALTTIINA NÄKYMÄTTÖMÄLLE LASERSÄTEILYLLE. ÄLÄ KATSO SÄTEESEEN.

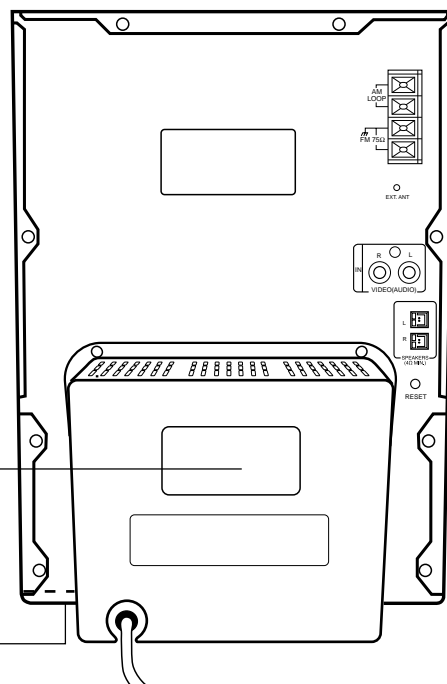

CAUTION - USE OF CONTROLS OR ADJUSTMENTS OR PERFORMANCE OF PROCEDURES OTHER THAN THOSE SPECIFIED IN THE OPERATING INSTRUCTIONS MAY RESULT IN HAZARDOUS RADIATION EXPOSURE.
THE PRODUCT SHOULD NOT BE ADJUSTED OR REPAIRED BY ANYONE EXCEPT PROPERLY QUALIFIED PERSONNEL.

- The apparatus shall not be exposed to dripping or splashing.
- Do not use where there are extremes of temperature (below 5°C or exceeding 35°C) or where direct sunlight may strike it.
- Because of the CD player's extremely low noise and wide dynamic range, there might be a tendency to set the volume on the amplifier unnecessarily high. Doing so may produce an excessively large output from the amplifier which could damage your speakers.
- When carrying the unit, be sure to remove a disc which may be inside and turn the power off. Wait at least 10 seconds, then unplug the mains lead from the AC outlet. Carrying the unit with a disc inside may damage the disc and/or the unit.
- Sudden changes in the ambient temperature may cause condensation to form on the optical lens inside the unit. If this happens, take out the disc, leave the unit for about 1 hour, and then proceed to operate.
- The system's speakers use powerful magnets. Do not place timepieces, credit cards, cassette tapes or video tapes, etc. near the speakers.
- Do not install this equipment in a confined space, such as a book case or built in cabinet.
- No object filled with liquids, such as vases, shall be placed on the apparatus.

CONNECTIONS

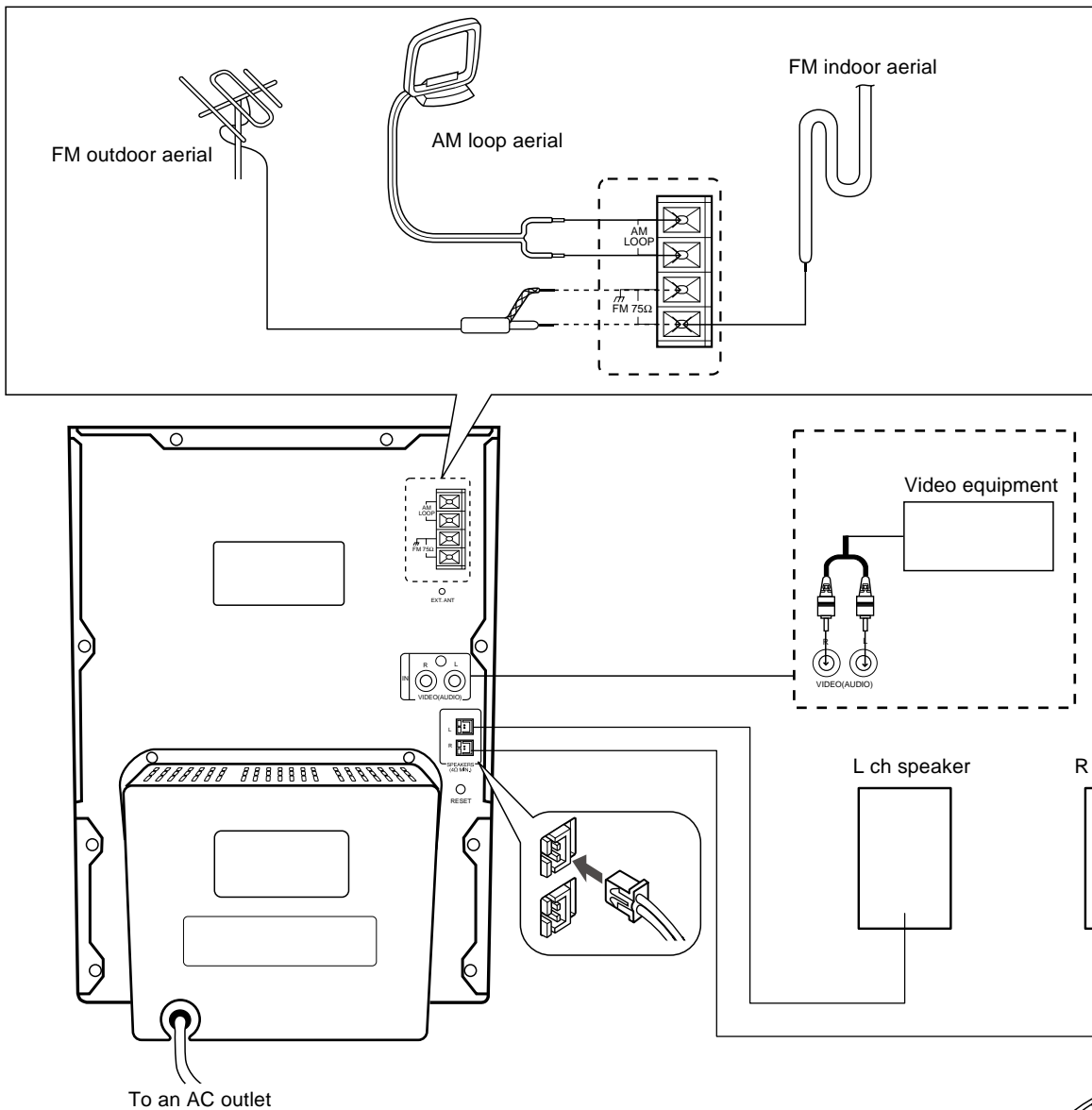

Note:

- Do not connect the mains lead to an AC outlet until all connections have been made.
- The system is not completely disconnected from the mains when the ⏻ /ON button is set to the ⏻ position.

Speakers

Connect the connector of the left speaker lead to the "L" SPEAKERS socket and the connector of the right speaker lead to the "R" socket. If you have difficulty inserting the speaker lead connector, turn it over and reinsert it.

FM aerials

The FM indoor aerial is sufficient to receive most local FM broadcasts and should be connected to the FM 75Ω terminal. Extend the aerial wire as straight as possible and, while listening to the sound from the system, secure it in a position which yields minimal distortion and noise. In fringe areas or where reception is distorted or noisy, an FM outdoor aerial (not supplied) should be connected instead of the simple indoor aerial. Consult your dealer.

AM loop aerial

Assemble the loop aerial as shown in figure.

Unwind the aerial wires, then connect them to the AM LOOP terminals. Place the loop aerial in a position which yields the best AM reception, or attach it to a wall or other surface as shown in figure.

Note:

To minimize noise, the speaker, mains and any other leads should not come close to the FM indoor or outdoor aerial lead and AM loop aerial. Do not place the aerial leads close to the system.

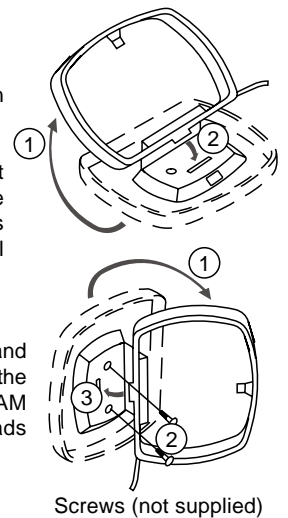

Video/Auxiliary equipment

Connect audio leads (not supplied) from the audio output sockets of a video equipment to the VIDEO (AUDIO) sockets.

Headphones

Connect stereo headphones (not supplied) to the PHONES socket for monitoring or for private listening. The speakers are automatically disconnected when headphones are connected.

CONTROLS

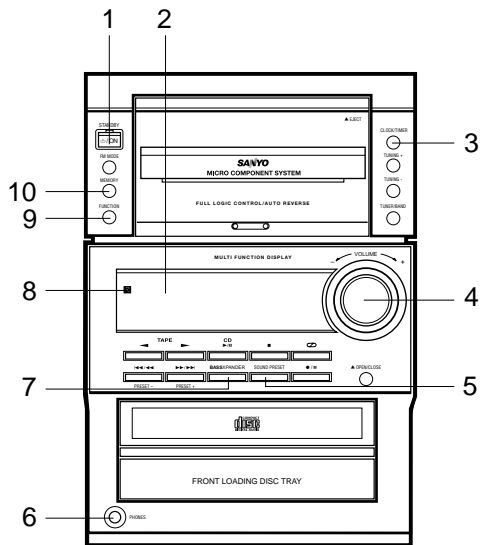

General

1. Power button/STANDBY indicator (⏻/ON, STANDBY)
2. Display
3. Clock/Timer button (CLOCK/TIMER)
4. Volume Control (VOLUME)
5. Sound preset button (SOUND PRESET)
6. Headphones socket (PHONES)
7. Bass expander button (BASSXPANDER)
8. Remote sensor (IR)
9. Function button (FUNCTION)
10. Memory button (MEMORY)

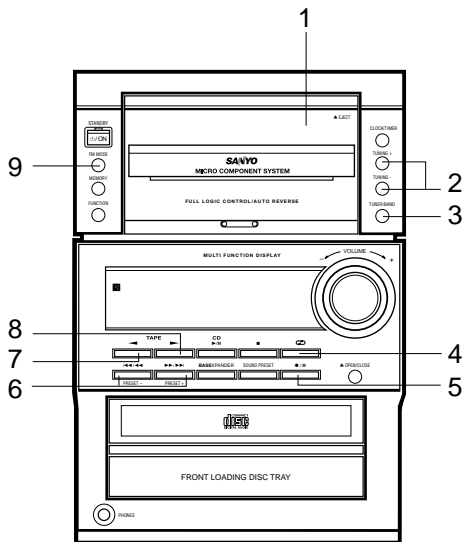

Tuner/Cassette

1. Cassette holder
2. Tuning buttons (TUNING +, TUNING -)
3. Tuner function/Band select button (TUNER/BAND)
4. Reverse mode button (⏮)
5. Record/Record pause button (●/||)
6. Fast forward/Rewind/Preset tuning buttons (⏩/⏪ / PRESET +, ⏮/⏭ / PRESET -)
7. Reverse play button (◀)
8. Forward play button (▶)
9. FM mode button (FM MODE)

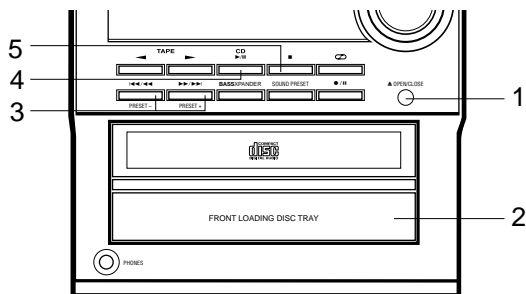

CD player

1. Open/Close for the disc tray button (▲ OPEN/CLOSE)
2. Disc tray
3. Skip/Search buttons (⏮/⏭ / PRESET -, ⏩/⏪ / PRESET +)
4. Play/Pause button (▶/||)
5. Stop button (■)

REMOTE CONTROL

Controls

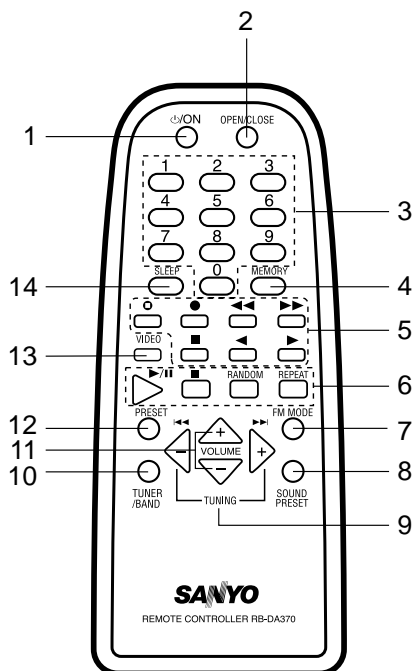

1. Power button (⏻/ON)
2. Open/Close button for disc tray (OPEN/CLOSE)
3. Number buttons (1-9, 0)
4. Memory button (MEMORY)
5. Cassette deck controls
 - : Record muting button
 - : Record/Record pause button
 - ◀◀, ▶▶: Fast forward/Rewind buttons
 - ◀: Reverse play button
 - ▶: Forward play button
 - : Stop button
6. CD player controls
 - ▶/||: Play/Pause button
 - : Stop button
 - RANDOM: Random play button
 - REPEAT: Repeat button
7. FM mode button (FM MODE)
8. Sound preset button (SOUND PRESET)
9. Tuning buttons (TUNING +, -, ◀◀, ▶▶)
(These buttons can also be used as CD playing tracks skip and search button)
10. Tuner function/Band select button (TUNER/BAND)
11. Volume buttons (VOLUME +, -)
12. Preset tuning button (PRESET)
13. Video function button (VIDEO)
14. Sleep button (SLEEP)

Number buttons (1 - 9, 0)

These buttons are used to select the track numbers on a disc or preset radio stations.

If the function is "CD", the buttons select the track numbers on a disc. If the function is "TUNER", the buttons select preset radio stations.

With any other function, the buttons will not function.

- Two buttons must always be pressed.

Example:

To select No. 3, press 0, then 3.

To select No. 10, press 1, then 0.

To select No. 25, press 2, then 5.

Inserting batteries

1

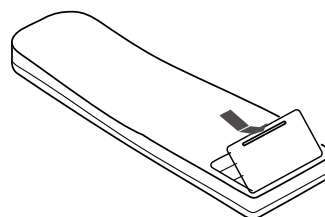

2

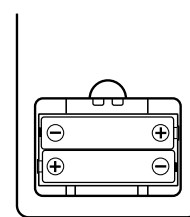

Two R03/AAA batteries
(not supplied)

Note:

Always remove batteries if the remote control is not to be used for a month or more. Batteries left in the unit may leak and cause damage.

Remote control range

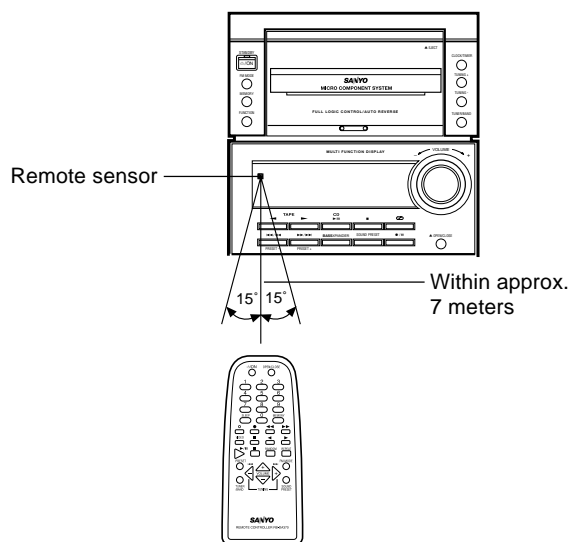

The buttons on the remote control perform similar functions to similarly marked buttons on the front panel.

ADJUSTING THE CLOCK (Main unit only)

When the unit is first connected to the AC power line, the display enters automatically the demonstration mode. To cancel this mode, turn the power on or press the CLOCK/TIMER button.

Example: To set "PM 6:30",
First, press the \odot /ON button to turn the power off. Only the clock display appears dimly.

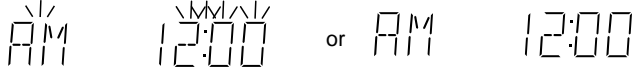

1. Press the CLOCK/TIMER button for at least 2 seconds. The clock display lit up and " \odot " blinks on the display.

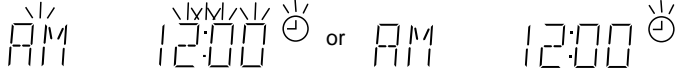

2. Press the MEMORY button.

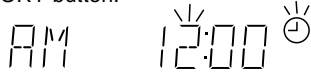

The hours display blinks.

3. Turn the VOLUME control to set the "hours".

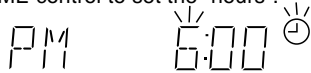

4. Press the MEMORY button.

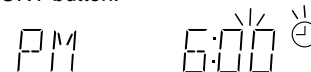

The minutes display blinks.
5. Turn the VOLUME control to set the "minutes".

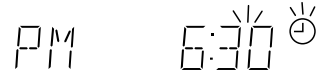

6. Press the MEMORY button. The clock starts.



- The time can be set accurately by pressing the MEMORY button when a time signal is heard.

- To display the clock during operation, press the CLOCK/TIMER button briefly. After a few seconds, the original display returns.

- If a power failure occurs or the mains lead is disconnected, and the clock display blinks. Reset the time again.

Changing the clock to the 24-hour display

1. Press the \odot /ON button to turn the power off, and the present time display.

2. While clock is displaying, press the MEMORY button and hold it, then press the \blacksquare button.

Example: PM 1:00 \rightarrow 13:00

To return the original setting, repeat steps above.

BEFORE OPERATION

Turning the power on and off

Press the \odot /ON button, the STANDBY indicator goes out, the display lights and "WELCOME" appears briefly. (After connecting the mains lead, when you press the \odot /ON button for the first time, the volume reset feature automatically sets the initial volume level.)

To turn the power off, press \odot /ON button again. The STANDBY indicator lights and "GOOD BYE" appears briefly. The clock display remains lit dimly. (If the clock has not been set, the display enters the demonstration mode.)

- When the mains lead is connected to the AC outlet, the unit will respond to commands from the remote control.

Direct start function

If the following buttons are pressed when the unit is in standby, the unit turns on automatically and the selected function is set.

CD section	\blacktriangleright /II
	\blacktriangle OPEN/CLOSE
Deck section	\blacktriangleleft , \blacktriangleright
Tuner section	TUNER/BAND
Remote control	\blacktriangleright /II, OPEN/CLOSE, \blacktriangleleft , \blacktriangleright , TUNER/BAND, VIDEO

Selecting the function

Press the FUNCTION button to select the desired function. Each time the button is pressed, the display changes as follows:

CD \rightarrow TAPE \rightarrow TUNER \rightarrow VIDEO \rightarrow CD \rightarrow ...

The function is automatically selected when CD play or tape playback is started or when the TUNER/BAND button has been pressed (except during recording).

- When the function selection is changed, CD play or tape playback is automatically stopped.

Adjusting the volume

Turn the VOLUME control, or press the + or - VOLUME button on the remote control. The volume level appears by numbers (VOL MIN ~ VOL MAX) on the display.

Bass expander system

Press the BASSXPANDER button to enhance the bass sound. "BASS" appears on the display.

Selecting the sound mode

Press the SOUND PRESET button to select the sound mode matching the music to be listened to.

- POP: Pops, etc.
- CLASSIC: Classical music, etc.
- ROCK: Rock music, etc.
- JAZZ: Jazz, etc.

WHAT TO DO IF ...

If the operation of the unit or display is not normal,

1. Disconnect the mains lead.
2. Press the RESET button (rear of the unit) for at least 30 seconds.
3. Connect the mains lead.
4. Resume the operation.

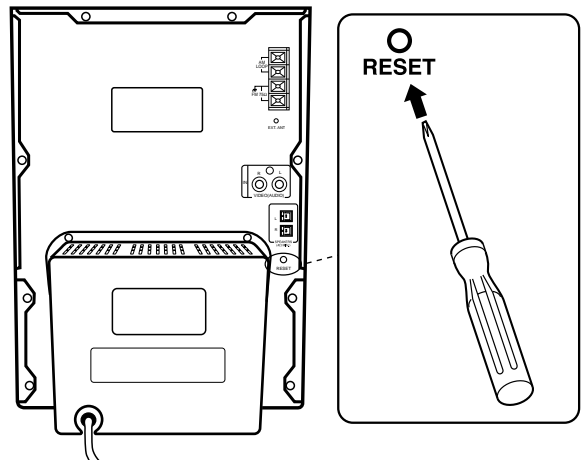

CD PLAY

Use compact discs bearing the symbol shown. In addition to conventional 12 cm CDs, this system can be used to play 8 cm CDs without an adapter.



If disc is loaded, you can turn the unit on and begin play immediately by pressing the ►/|| button.

1. Press the FUNCTION button to select "CD" function. "CD" appears on the display, then "CD" is replaced by the CD mode display.
2. Press the ▲ OPEN/CLOSE button to open the disc tray, "OPEN" appears.
3. Place the disc with the label facing up on the disc tray. (Place only one disc at a time.)
4. Press the ▲ OPEN/CLOSE button again to close the disc tray. "CLOSE" appears briefly, then the total number of tracks and total playing time on the disc appear.

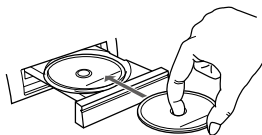

Note:

If the disc is loaded with the label facing downward, or if a badly scratched disc is loaded, "NO DISC" appears. If this occurs, load the disc correctly or replace the damaged disc.

5. Press the ►/|| button. Play starts from the first track. The current track number and elapsed playing time are displayed. 
6. Press the ■ button to end disc play. When the last track has been played, the player stops automatically.

Notes on handling compact discs

- Do not expose the disc to direct sunlight, high humidity or high temperatures for extended periods of time.
- Discs should be returned to their cases after use.
- Do not apply paper or write anything on the disc surface.
- Handle the disc by its edge. Do not touch the playing surface (glossy side).
- Fingerprints and dust should be carefully wiped off the playing surface of the disc with a soft cloth. Wipe in a straight motion from the centre to the outside of the disc.
- Never use chemicals such as record cleaning sprays, antistatic sprays or fluids, benzene or thinner to clean compact discs.

To start play from the desired track

Select the track by using the ►►/►►| or |◄◄/◄◄ button.

Using the remote control

Press two number buttons within 4 seconds. (Example: press 0, then 3.)

Temporarily stopping play

Press the ►/|| button. "►" blinks on the display. To resume play, press the button again.

Skip play

To skip to track 6 while track 3 is playing, press the ►►/►►| button repeatedly until "6" appears (in the track section) on the display. To skip back to track 3 while track 6 is playing, press the |◄◄/◄◄ button repeatedly until "3" appears.

- The number buttons on the remote control can also be used for skip play. To skip to track 6 while one track is playing, press 0, then 6.

Search (forward/reverse)

If the ►►/►►| or |◄◄/◄◄ button is pressed during play, the player will search at high speed in the forward or reverse direction while the button is being pressed. When the button is released, normal play will continue.

Random play (Remote Control only)

Press the RANDOM button to begin random play. The player will automatically select and play tracks on the disc at random. "RANDOM" appears on the display.

- Random play will not function during programmed play.



Repeat play (Remote Control only)

Press the REPEAT button before or during play. The player will play all the tracks or all the programmed tracks repeatedly. "REPEAT" appears on the display. To cancel repeat play, press the REPEAT button again. "REPEAT" disappears.

PROGRAMMED PLAY

Up to 24 tracks on a disc can be programmed for play in any order.

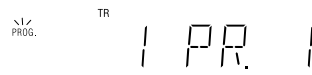
- First, select "CD" function and load a disc that you want to programme.
- The tracks must be programmed in the stop mode.
- The same track can be programmed more than once.

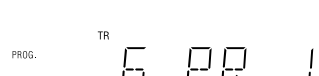
1. Press the MEMORY button. 
2. Select a track by using the ►►/►►| or |◄◄/◄◄ button. The number buttons on the remote control can also be used. 
3. Press the MEMORY button. 

4. Repeat steps 2 - 3 to programme additional tracks.
5. Press the ►/|| button to start programmed play.

When all programmed tracks have played, the player stops automatically. "0 0.00" appears on the display. 

- The programme contents are retained in memory.

- Any attempt to programme more than 24 tracks will result in "FULL" being displayed and discontinuation of the programming.
- To cancel programmed play, press the ■ button twice.

Checking the programme

Each time the MEMORY button is pressed in the stop mode, the programmed details sequentially appear on the display.

Changing a programme

To add a new track to a programme:

1. In the stop mode, press the MEMORY button repeatedly until "- - - -" is displayed.
2. Select a track as explained above.
3. Press the MEMORY button.

To change a track:

1. In the stop mode, press the MEMORY button repeatedly until the track number to be replaced is displayed.
2. Select a track as explained above.
3. Press the MEMORY button.

Note:

Programmed details cannot be partially deleted or inserted.

LISTENING TO TAPES

If a cassette is loaded, you can turn the unit on and begin play immediately by pressing the ► or ◀ button.

1. Press the FUNCTION button to select "TAPE".
2. Press the cassette holder (▲ EJECT portion) to open it.
3. Load the cassette.

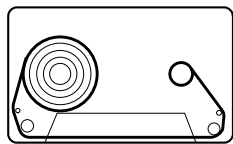

4. Press the ◀ button to select the reverse mode as desired.

◀: For listening to one side of the tape only.

◀▶: For listening to both sides of the tape in succession.

- If playback has been started from the reverse side, only the reverse side will be played back.

◀▶: For listening repeatedly to both sides of the tape.

5. Press the ► or ◀ button to begin playback. "►" or "◀" appears.
 - : For forward play
 - ◀: For reverse play.
6. Press the ■ button to stop playback at any time. When the end of the tape has been reached, automatic stop or reverse will be activated.

Note:

- Use the normal tape (TYPE 1).
- Endless tapes cannot be used.
- Do not use C-100 (or longer) tapes. They may jam in the mechanism.

Fast forward and rewind

Press the ►►/►► or ◀◀/◀◀ button. "►" or "◀" blinks. When the desired location has been reached, press the ■ button.

LISTENING TO THE RADIO

Before use

When the unit is shipped from the factory, its AM frequency band is set as "522 - 1710 kHz (in 9 kHz steps)".

If your local AM broadcast system is organized in 10 kHz steps, change the frequency band to "520 - 1710 kHz (in 10 kHz steps)" as follows.

1. Press the TUNER/BAND button to select "AM".
2. While pressing the MEMORY button on the front panel, press the TUNER/BAND button on the front panel.

To return the original setting, repeat steps above.

To turn the unit on and listen to the last received station, press the TUNER/BAND button.

Automatic/Manual tuning

1. Press the TUNER/BAND button to select AM or FM.
 - "TUNER" is selected automatically. "TUNER" appears on the display, then "TUNER" is replaced by the tuner mode display.

Automatic tuning

Press the TUNING - or TUNING + button for at least 1 second to tune in a station. The unit will scan up or down the band and receive the next receivable station. Press the button again to continue.

Manual tuning

Press the TUNING - or TUNING+ button briefly until the desired frequency is displayed.

FM 103.25 MHz

To preset stations

Up to 24 stations for FM band, 12 stations for AM band can be preset.

Automatic presetting (APT)

1. Press the TUNER/BAND button to select AM or FM.
2. Press the MEMORY button for at least 3 seconds. "PROG." blinks. The automatic tuning mode is set and automatic presetting begins from the low end of the band. When 24 stations for FM, 12 stations for AM have been preset or the high end of the band is reached, automatic presetting stops. "PROG." disappears and the previous received station is heard.
3. To preset stations on the other band, follow steps above.

Note:

If APT is activated, all previously programmed stations of the band will be cleared and new stations will be programmed.

Manual presetting

1. Tune in the station to be preset as described in "Automatic/Manual tuning".

2. Press the MEMORY button.

PROG. CH 103.25 MHz

3. Press the PRESET - or PRESET + button on the front panel (or PRESET button on the remote control) to select the channel number to be preset.

PROG. CH 9 103.25 MHz

4. Press the MEMORY button.

- In this example, "103.25 MHz" FM station is preset on FM channel 9.

- The number buttons on the remote control can be used to preset the station directly. In this example, press 0, then 9 after the step 2 above.

FM 103.25 MHz

Note:

If the next step is not taken within 10 seconds while performing steps 2 - 4, "PROG." disappears and the preset operation is cancelled. Press the MEMORY button to continue.

5. Repeat steps above to add more preset stations.

- When presetting a new station, the previous preset station is cleared.

Listening to preset stations

1. Press the TUNER/BAND button to select AM or FM.
2. Press the PRESET - or PRESET + button on the front panel (or PRESET button on the remote control) to select the desired channel number. The selected channel number appears briefly.
 - The number buttons on the remote control can also be used. Press two number buttons within 2 seconds.

Preset scan tuning

1. Press the TUNER/BAND button to select AM or FM.
2. Press the PRESET - or PRESET + button (or the PRESET button on the remote control) for at least 1 second.
 - The channel number blinks.
 - The preset stations are selected in sequence for approximately 5 second each.
3. Press the PRESET - or PRESET + button (or the PRESET button on the remote control) when the desired station has been selected. Preset scanning will stop.

To receive FM stereo broadcasts

"ST" appears when an FM stereo broadcast is received in the stereo mode.

- If the signal from an FM stereo station is weak and reception is poor, press the FM MODE button to change to the mono mode. The reception may be improved, but the sound will be monaural.

When beat interference is heard

A high-pitched noise called "beat" is sometimes heard during reception of radio broadcasts. If this occurs.

1. Press the MEMORY button.
2. When "PROG." is blinking, press the FM MODE button to select "bc-A" or "bc-B". Select the setting that gives the best results.





LISTENING TO OTHER SOURCES

1. Press the FUNCTION button to select "VIDEO".
2. Follow the instructions supplied with the video equipment.







RECORDING

Recording copyright material without permission of the copyright owners is usually an infringement. If you wish to re-record copyright material, permission from the copyright owner is necessary. SANYO does not approve of, and cannot be held responsible for, any unlawful use of this machine.





Preparation

1. Press the FUNCTION button to select "TAPE".
2. Load a blank cassette.
3. Press the  button to select the reverse mode.
 - : For recording one side only.
 - : For recording both sides in succession.
- If recording has been started from the reverse side, only the reverse side will be recorded.
- If a tape with one of its tabs already broken out is used for recording, the tape will not be reversed automatically, and it will stop.
- If the reverse mode has been set to "", "" appears automatically when the recording mode is established.

Recording compact discs (Synchronous recording)

1. Select "CD" function.
2. Load the disc to be recorded.
 - For programmed recording, programme the material in advance (as described under "PROGRAMMED PLAY").
3. Select the track number to be recorded if required.
 - For programmed recording, this step is unnecessary.
4. Press the  button (or the  button on the remote control). The deck enters the recording pause mode and "REC" appears. " 
" blinks.5. Press the  or  button. Recording starts.
6. Press the  button to stop recording. Also the CD player stops automatically.

Recording from the tuner or other sources



1. Tune in the radio station to be recorded or play other sources.
2. Press the  button.
3. Press the  or  button. Recording starts.
4. Press the  button to stop recording.





When beat interference is heard

A high-pitched noise called "beat" is sometimes heard during the recording of radio broadcasts. If this occurs.

1. Press the MEMORY button.
2. While "PROG." is blinking, press the  button to select "bc-1" or "bc-2". Select the setting that gives the best results.

Automatic record muting (Remote control only)

Undesirable parts of a programme can be omitted while recording. Press the  button once while recording. "REC" blinks and a 5-second unrecorded blank space is created, then the deck enters the recording pause mode. "REC" remains lit and "" or "" blinks on the display.

- To add another 5-second blank space, press the  button again.
- To resume recording, press the  or  button (to match the blinking "" or "").

Safeguards against accidental erasure

Accidental erasure can be prevented by breaking out the tabs on the end of the cassette tape (where the tape is not exposed) using a screwdriver or similar implement.

If a tab is broken out in error and you wish to re-record the tape, simply block the tab hole using adhesive tape and the tape can be used for recording again.

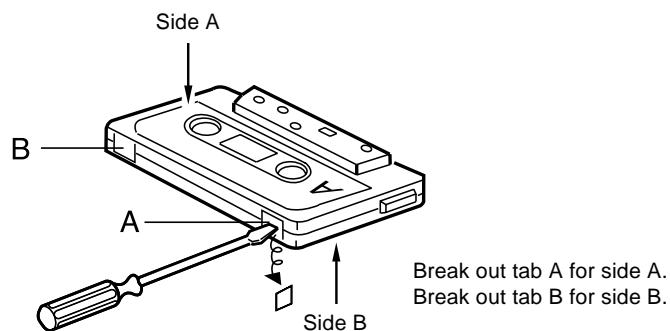

TIMER OPERATION

Using the timer (Main unit only)

Set the on and off times, and function to be used. Operation will start with the selected function at the on time. The sound will be gradually increased from a no-sound level to the current volume setting (fade-in). The power will be switched off at the off time. The timer will function every day unless it is released.

Preparation

Note:

Make absolutely sure that the clock is set to the correct time before setting the timer.

- Prepare the sources to be used.
 - If the function selected is tuner, tune in to the desired band and station.
 - For cassette deck: Tape playback will start in the forward direction.
- Adjust the volume level as desired.

Operation

1. Press the FUNCTION button to select the function and set the desired volume level for timer operation.
2. Press the CLOCK/TIMER button for at least 2 seconds.

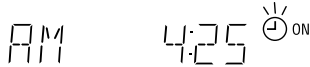

The previous timer on time setting appears.

3. Press the MEMORY button within 10 seconds.

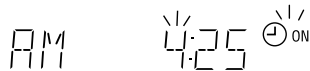

4. Set the timer on time by turning the VOLUME control, then press the MEMORY button (as described under "ADJUSTING THE CLOCK").

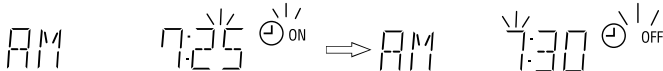

The timer off time setting appears.

5. Set the timer off time as described in step 4.



The previous timer mode/function setting appears.

- "ON" blinks only for tuner function, "ON" remains lit for other function.
6. Select the timer mode by turning the VOLUME control (Tuner function only).
 - "REC" and "ON" blink alternately. Select "REC" for unattended recording.
 7. Press the MEMORY button (Tuner function only).

The original display returns, then the timer operation standby mode is activated. "ON" or "REC" remains lit.
 8. Press the ON/OFF button to switch off the power.
 - To switch off the power during a timer controlled operation, press the ON/OFF button. The timer will be set in the standby mode.

To release the timer

After turning the power on, press the CLOCK/TIMER button twice. "ON" or "REC" disappears.

To set the timer again with the same settings

1. Press the CLOCK/TIMER button repeatedly to display "ON" or "REC".
2. Press the ON/OFF button to switch off the power.

Note:

The timer operation is released if a power failure occurs.

Using the sleep timer (Remote control only)

The sleep timer automatically switches off the power after a preset time has elapsed. The volume will gradually be reduced (fade-out) during the 1-minute period before the unit turns off. There are 12 time periods available: 120, 110, 100, 90, 80, 70, 60, 50, 40, 30, 20, and 10 minutes.

Press the SLEEP button repeatedly to select the desired sleep time. "SLEEP" blinks and the selected time appears on the display. After a few seconds, the original display returns. "SLEEP" remains blinking.

To check the remaining sleep time

Press the SLEEP button once. After a few seconds, the original display returns.

To release the sleep timer while in operation

Press the SLEEP button repeatedly until "SLEEP" disappears. The timer is also released if the power is switched off.

MAINTENANCE

Cleaning the tape heads

To ensure continued high performance, use cotton swab to clean the heads, pinch rollers and capstan of the deck after about every 10 hours of use. If the dirt persists, soak the swab in a little methylated spirit or head cleaning fluid and then clean.

Cleaning the unit

Clean the outside of the unit with a clean soft cloth, moistened with lukewarm water. Do not use benzene, thinner or alcohol since they will mar the finish of the surfaces.

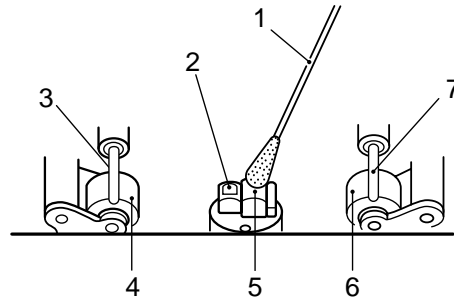

- 1. Cotton swab
- 3, 7. Capstan
- 4, 6. Pinch roller
- 2, 5. Head

SPECIFICATIONS

Tuner

Reception frequency:

FM: 87.5 - 108 MHz

AM: 522 - 1710 kHz (in 9 kHz steps)

520 - 1710 kHz (in 10 kHz steps)

CD player

Channels:

2-channel stereo

Sampling frequency:

44.1 kHz

Pick-up:

Optical 3-beam semiconductor laser

Laser output:

0.6 mW (Continuous wave max.)

Wave length:

790 nm

Wow/flutter:

Below measurable limits

Cassette deck

Track system:

4-track, 2-channel stereo

Frequency response:

60 Hz to 13.5 kHz

Signal-to-noise ratio:

50 dB

Wow/flutter:

0.12% (WRMS)

Fast forward/rewind time:

Approx. 110 sec. (C-60)

General

Output power:

12.5 W x 2 (at 4 ohms, 10% distortion)

Input:

VIDEO IN: 500 mV/50k ohms

Outputs:

SPEAKERS: 4 ohms

PHONES: 8 - 32 ohms

Power requirements:

AC 230V ~ 240V, 50 Hz

Power consumption:

35 W

Dimensions:

200(W) x 281(H) x 278(D) mm

Weight:

4.0 kg

Speaker systems

Type:

Full range bass reflex

Unit used:

10 cm cone type

Maximum power-handling capacity:

25 W (peak)

Nominal impedance:

4 ohms

Dimensions:

181(W) x 280(H) x 205(D) mm

Weight:

2.6 kg (per speaker)

Specifications subject to change without notice.

