

## Notice

- CORRECTION       PRODUCTION CHANGE  
 SERVICE FLASH       ADD INFORMATION

FILE NO. C-2042

Please add this notice to the Service Manuals listed below.

REVISION 3

Category : Liquid Crystal Colour Video Projector

Date : Mar., /10 /1998

Model : PLC-220P/PB/PP

Service Ref. No. PLC-220P/PB/PP-00

Europe, Asia, Africa, M.E./UK/

Destination : Australia, NewZealand REF : No. SM525014

## LCD PANEL REPLACEMENT NOTE

It is necessary to change the circuit when all three panels (R, G, B) are replaced for the projectors with serial numbers (The Serial No. is shown on the rating plate). listed in the table on the right. Follow the procedure described below to change the circuit.

MODEL NO.	SERIAL NO.
PLC-220P	G4901001 ~ G4X01500
PLC-220PB	G4X01001 ~ G4901100
PLC-220PP	G4X01001 ~ G4X01050

1. Cut to foil at point A.
2. Take the No. 9 pin of the IC404 off from the foil, and solder it and point B with a wire lead.
3. Take the No. 5 pin of the IC404 off from the foil, and solder it and point C with a wire lead.
4. Solder the point D and E with a wire lead.

## COMPONENT AND TESTPOINT LOCATIONS TIMING & LC DRIVE BOARD (COMPONENT SIDE)

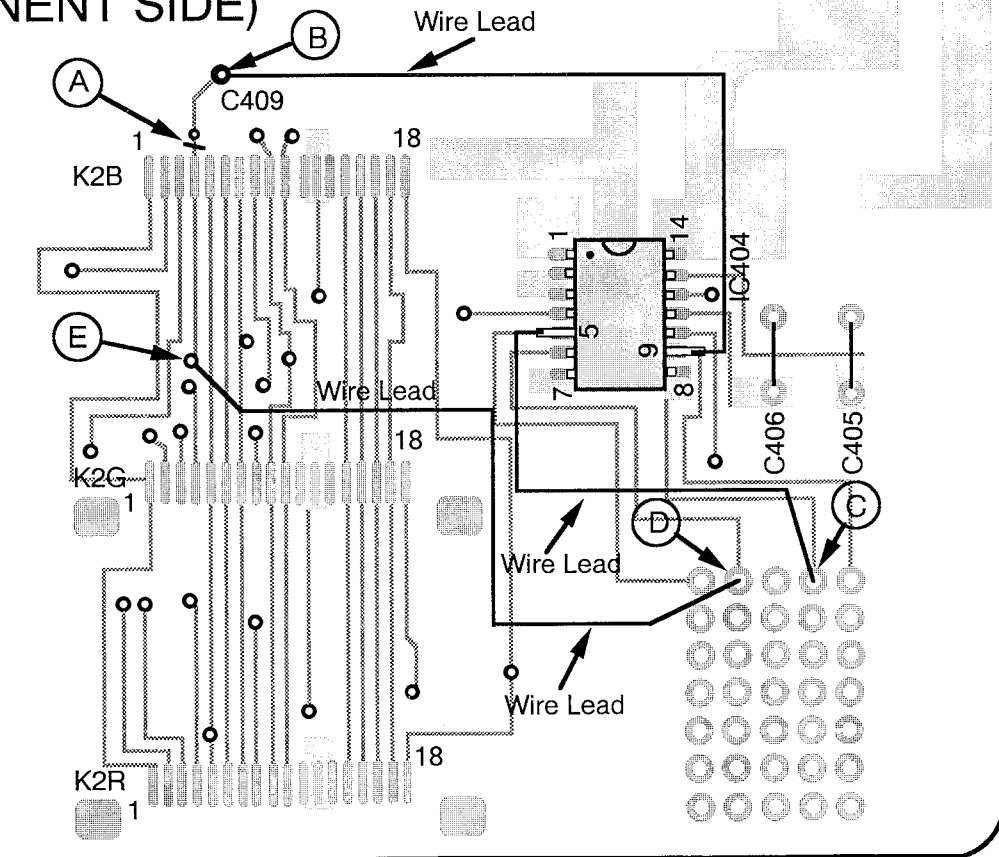

Prod. Code : 1122 008 00, P4AA  
 1122 008 01, P4AB  
 1122 008 02, P4AC

REFERENCE No. SM525014-03

# SCHEMATIC DIAGRAMS

## TIMING & LC DRIVE BOARD

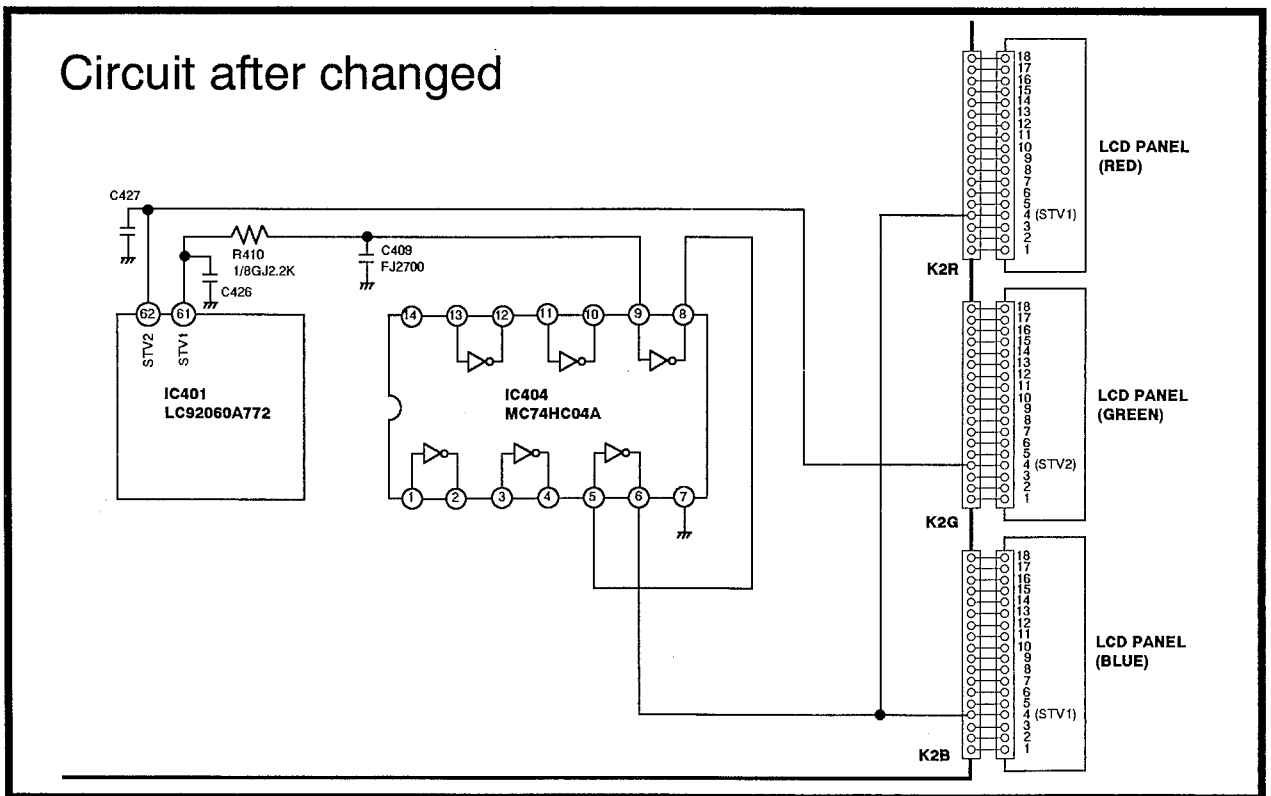
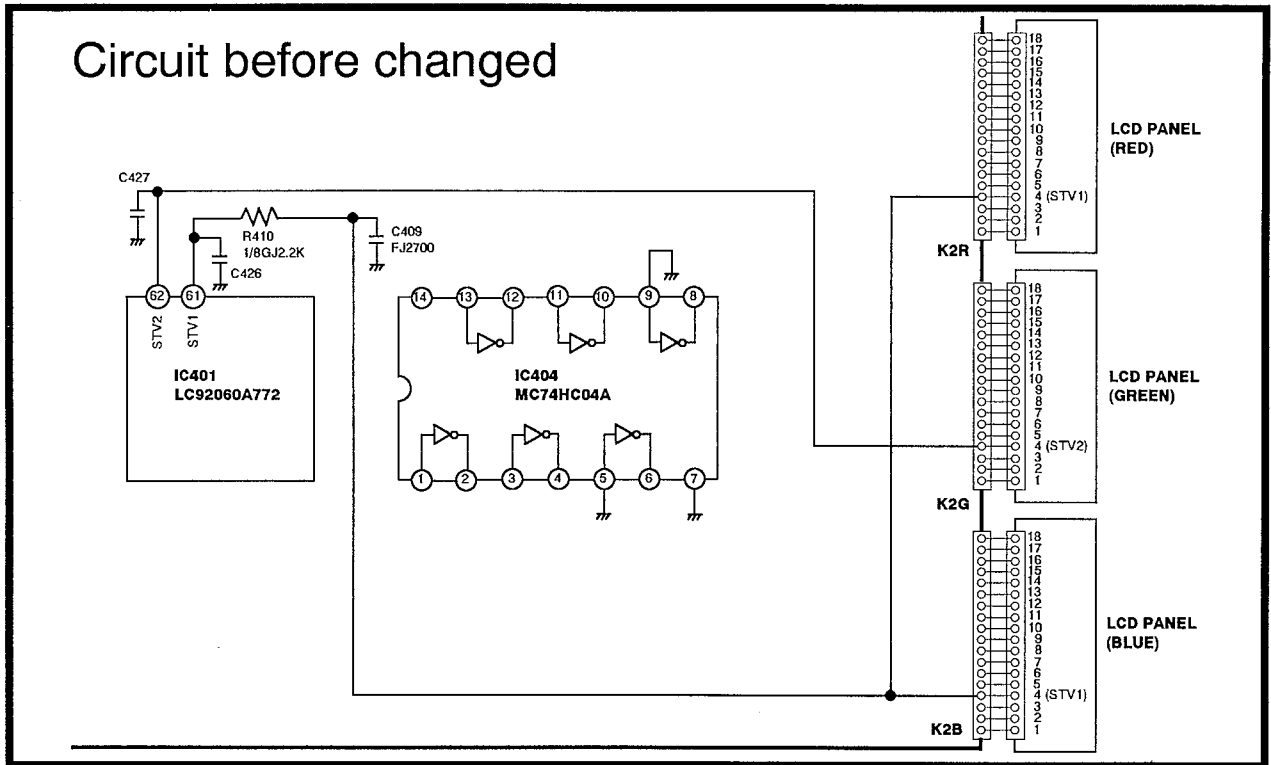

**SANYO**

SANYO Electric Co., Ltd.  
Printed in Japan